

Print Number:

Print Date:

NOBLELIFT



Scan QR Code for More

Electric double stacker PT20D

PARTS MANUAL

561146020101

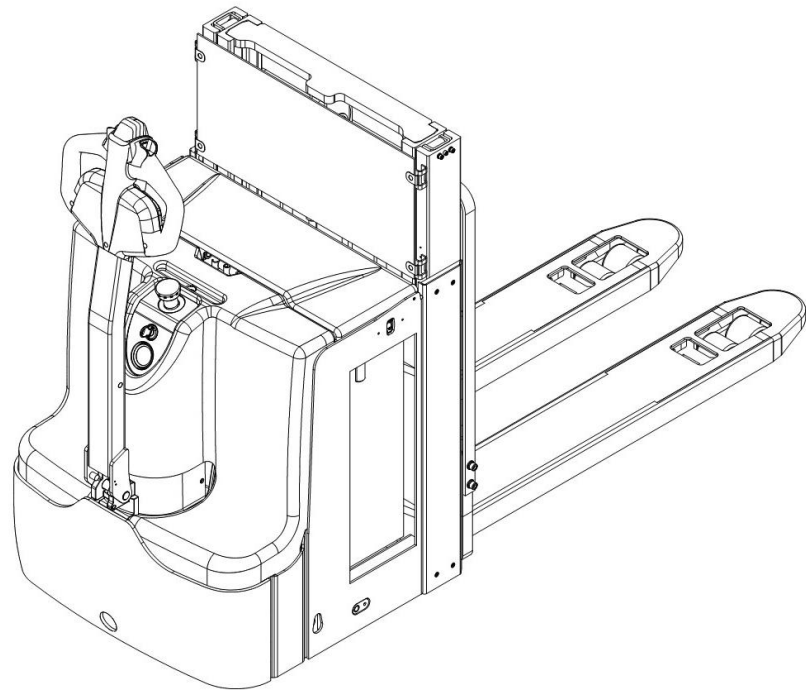

Version: V04

Truck Identification Number From:

Parts Manual

PT20D-PM04EN

Please order spare parts from authorized dealers of Noblelift Intelligent Equipment Co., LTD.

In order to avoid wrong delivery, all the orders for spare parts should specify the following items:

- Truck model, identification number and manufacture year.
- Orders for spare parts of mast, hydraulic transmission unit, steering axle, motor, etc. shall indicate the manufacture number of these parts.
- Codes for Noblelift spare parts are shown in the table of parts manual. Please also pay attention to the description of supply status, order quantity, etc. (check the number listed in "Mark" column of the parts manual).

"Mark" Column:

The unmarked indicates the parts are in short supply cycle.

Number 1: supply as package. Indicating these that parts are small parts and seal parts, which are supplied in package unit and in short supply cycle.

Number 2: supply with constraints. Indicating that these spare parts are not in stock and will be prepared for production after receiving the order from customers, which are in long supply cycle.

Number 3: phasing-out supply. Indicating that these parts will be replaced by new parts due to technical improvements and the current stock will not be available when these parts run out. Please check the description of technical improvements notice.

Number 4: supply as assembly. Indicating that these parts are assembly parts defined by manufacture process, which cannot be supplied as a single part.

Number 5: check other tables.

This parts manual is the property of Noblelift and can be shared under the confidential agreement only, Noblelift has the right to claim for compensation of any unauthorized use. Copy without permission is not allowed. Figures in the manual are not limited by the original design. Noblelift Intelligent Equipment Co., LTD reserves the right to improve the products for continuous technology progress.

Table of Contents

Chapter 1: Drive System.....	5
01 Drive Unit-Manual Steering (560846013502).....	5
02 Drive Assembly 1.3kW (560846013001)	7
Chapter 2: Hydraulic System.....	9
01 Hydraulic Components (560846024502,PT20D One-stage)	9
01 Hydraulic Components (560846024502,PT20D One-stage) Continuation	11
02 Hydraulic Components (561146024501,PT20D)	13
03 Hydraulic Unit (560846023502).....	15
Chapter 3: Truck Frame	17
01 Truck Frame (560846021502)	17
01 Truck Frame (560846021502) Continuation.....	19
02 Truck Frame (560846021503) (EN1175-2020)	21
02 Truck Frame (560846021503) (EN1175-2020)Continuation.....	23
Chapter 4: Chassis.....	25
01 Chassis (560846038502,PT20D One-stage).....	25
01 Chassis (560846038502,PT20D One-stage) Continuation	27
02 Chassis (560846038503,PT20D One-stage) (EN1175-2020)	29
02 Chassis (560846038503,PT20D One-stage) (EN1175-2020)Continuation	31
03 Chassis (561146038501,PT20D)	33
03 Chassis (561146038501,PT20D) Continuation.....	35
04 Chassis (561146038502,PT20D) (EN1175-2020)	37
04 Chassis (561146038502,PT20D) (EN1175-2020) Continuation.....	39
05 Fork Carriage (560846038002,PT20D One-stage Mast)	41
06 Fork Carriage (560846038003,PT20D One-stage Mast) (EN1175-2020).....	43
07 Fork Carriage (561146038001,PT20D Two-stage Mast).....	45
08 Fork Carriage (561146038002,PT20D Three-stage Mast).....	47
Chapter 5: Mast System.....	49
01 One-stage Mast Standard Lift (560846043001,PT20D One-stage)	49
02 Two-stage Mast Standard Lift (561146044001,PT20D).....	51
02 Two-stage Mast Standard Lift (561146044001,PT20D) Continuation	53
03 Two-stage Mast Standard Lift (561146044002,PT20D) (EN1175-2020)	55
03 Two-stage Mast Standard Lift (561146044002,PT20D) (EN1175-2020) Continuation	57
04 Three-stage Mast Standard Lift (561146045001,PT20D).....	59
04 Three-stage Mast Standard Lift (561146045001,PT20D) Continuation	61
05 Three-stage Mast Standard Lift (561146045002,PT20D) (EN1175-2020).....	63
05 Three-stage Mast Standard Lift (561146045002,PT20D) (EN1175-2020) Continuation	65
Chapter 6: Steering System, Braking System, Wheels	67
01 Tiller Unit (560846011001)	67
02 Control Handle (505646011003)	69
02 Control Handle (505646011003) Continuation.....	71
03 Load Wheel (Tandem) (560846017002).....	73
04 Caster (560846016502).....	75

05 Control Handle, detong (505646011002)	77
Chapter 7: Electrical Parts	79
01 Charger (560846036501)	79
02 Charger (560846036502)	81
03 Traction Battery (560846037002)	83
04 lithium battery (560846037002)	85
05 Controller, COMBIACX (560846033003)	87
06 Controller, Curtis-F (560846033002) (EN1175-2020)	89
07 Wire Harness,COMBIACX (560846033004)	91
08 Wire Harness, Curtis-F(561146033011) (EN1175-2020)	93
Chapter 8: Special Parts	95
01 Load Backrest (560846040502,PT20D One-stage)	95
02 Load Backrest (561146040501,PT20D)	97
Chapter 9: Others	99
01 Labels and Decals-EU (560846047003,PT20D One-stage)	99
02 Labels and Decals-US (560846047004,PT20D One-stage)	101
03 Labels and Decals-EU (561146047001,PT20D)	103
04 Labels and Decals-US (561146047002,PT20D)	105
Appendix	107
01 Hydraulic Circuit Diagram (560846045501)	107
02 Electrical Circuit Diagram, COMBIACX (560846045502)	108
03 Electrical Circuit Diagram, COMBIACX+Li (560846045503)	109
04 Electrical Circuit Diagram, F2C (561146045501)	110
05 Electrical Circuit Diagram, F2C+Li (561146045502)	111
06 Consumable Parts List	112

01 Drive Unit-Manual Steering (560846013502)

No.	Item Code	Mark	Item Description	Qty.	Substitute	Note
1	940700100001		Brake	1		
2	910200200060		Screw	8		
3	910400500006		Spring Washer	11		
4	560813510000		Wheel Mount	1		
5	910200200055		Screw	3		
6	534713520001		Bracket	1		
7	910200200075		Screw	4		
8	910400500007		Spring Washer	4		
9	910600400044		Spring Pin	2		
10	940900400002		Drive Unit	1		
11	910200200174		Screw	2		
12	910400100010		Flat Washer	2		
13	560813520013		Crash Pad	2		
14	271515520003		Washer	2		
15	560813520008		Spring	2		
16	560813520005		Stop Sleeve	2		
17	910300500008		Nut	2		
18	910200200013		Screw	2		
19	910400500003		Spring Washer	2		
20	560813520007		Mounting Plate	1		
21	940500200011		Bushing	2		
22	560813520006		Mounting Plate	1		
23	560813510002		Mounting Rack	1		
24	910200200034		Screw	6		
25	910300300003		Nut	6		
26	560813510001		Fixing Mount	1		
27	910200200005		Screw	2		
28	920200400001		Proximity Switch	1		

02 Drive Assembly 1.3kW (560846013001)

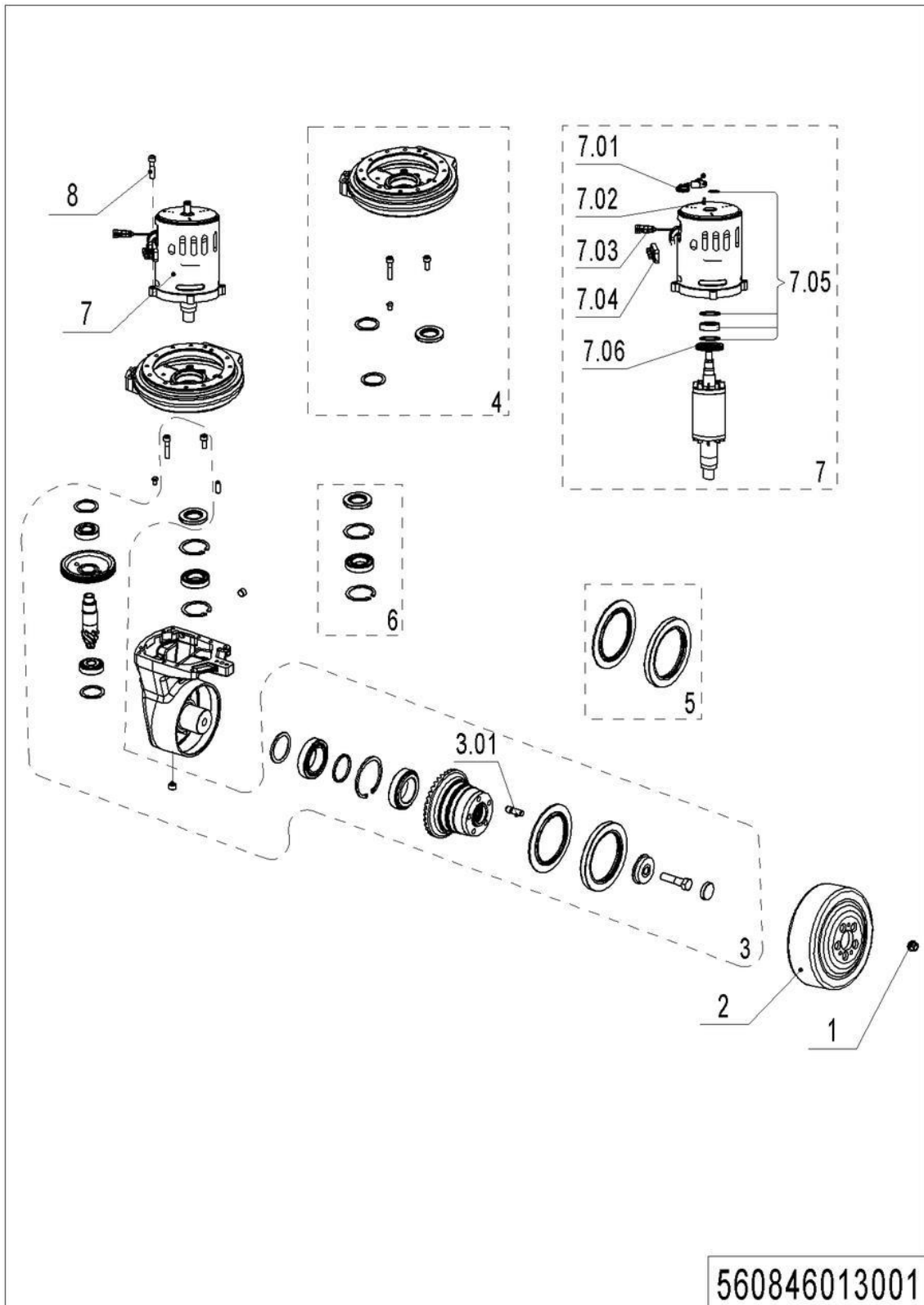

02 Drive Assembly 1.3kW (560846013001)

No.	Item Code	Mark	Item Description	Qty.	Substitute	Note
1	504498520003	2	Nut	5		
2	940300400005	2	WheelΦ230x70	1		
3	504498510001	2	Gear Ring	1		
3.01	504498520005	2	Bolt	5		
4	504498510002	2	Rotary Table Kit	1		
5	504498510003	2	Seal Kit	1		
6	504498510004	2	Bearing Kit	1		
7	504498510005	2	Motor	1		
7.01	504498520010	2	Sensor	1		
7.02	504498520011	2	Feather Key	1		
7.03	504498520012	2	Sensor	1		
7.04	504498520013	2	Wiring Board	1		
7.05	504498510006	2	Motor Kit	1		
7.06	504498520015	2	Sensor	1		
8	504498520016	2	Screw	4		

Chapter 2: Hydraulic System

01 Hydraulic Components (560846024502,PT20D One-stage)

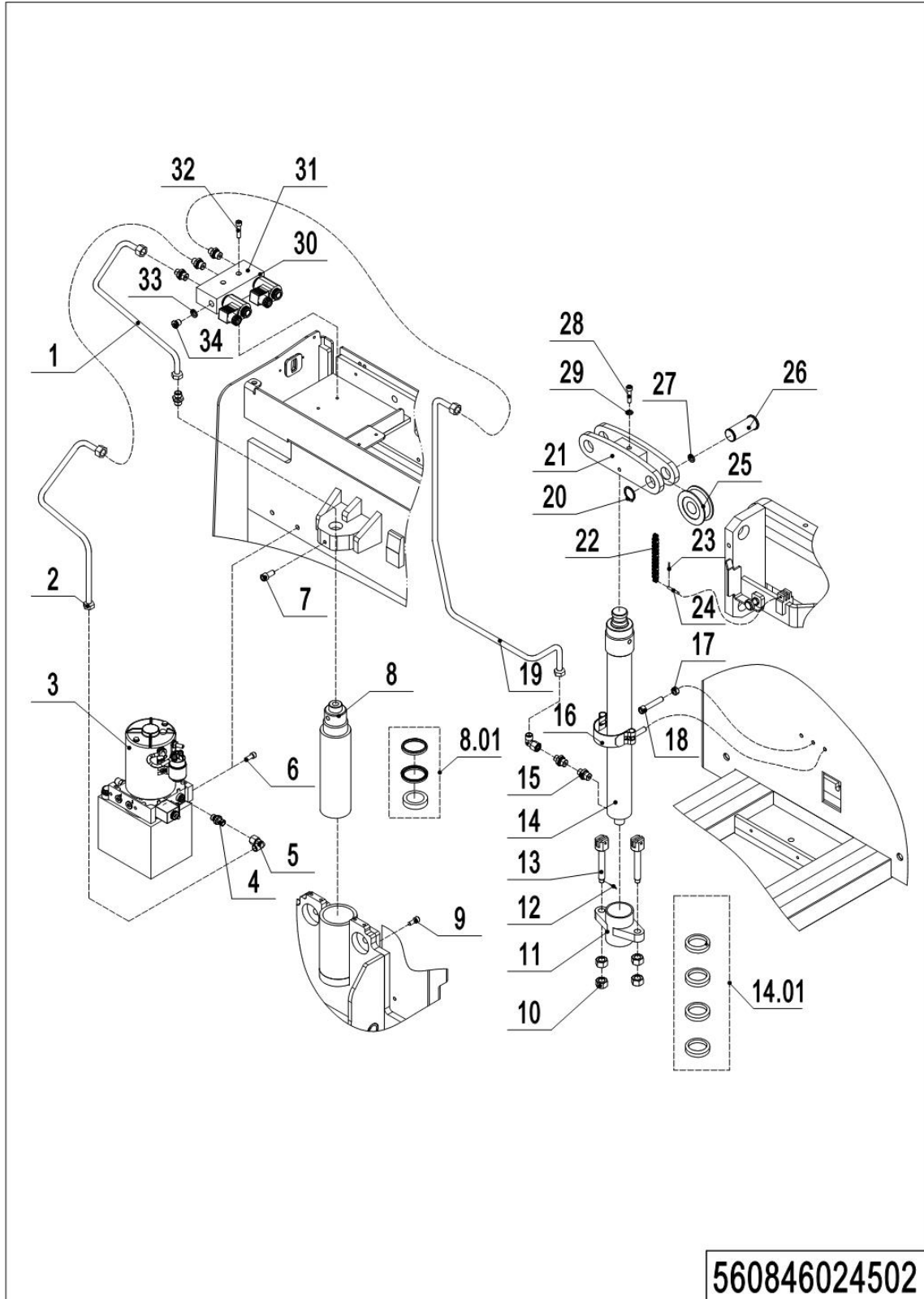

1=整包供货

2=限制供货

3=逐渐停止供货

4=不单件供货

5=见另外表单

01 Hydraulic Components (560846024502,PT2D One-stage)

No.	Item Code	Mark	Item Description	Qty.	Substitute	Note
1	560824520001		Steel Tube	1		
2	560824520000		Steel Tube	1		
3	950900100053		Pump Unit	1		
4	950400400003		Joint	6		
5	950400200003		Joint	2		
6	910200200074		Screw	2		
7	910200200055		Screw	1		
8	560824510001		Cylinder	1		
8.01	504498510000		Seal Kit	1		
9	910200200075		Screw	1		
10	910300200008		Nut	4		
11	560824510003		Pull Rod Base	1		
12	910600600037		Cotter Pin	2		
13	941300100005		Chain Bolt	2		
14	560824510002		Cylinder	1		
14.01	532098510010		Seal Kit	1		
15	950600300001		Safety Valve	1		
16	940800600003		Hoop	1		
17	910300100007		Nut	3		
18	910100300040		Bolt	1		
19	560824520002		Steel Tube	1		
20	910401300016		Circlip	2		
21	560824520007		Yoke	1		
22	560824510007		Chain	2		
23	910600600015		Cotter Pin	4		
24	941100800010		Pin	4		
25	940200500003		Sprocket Bearing	2		
26	560824520006		Axle	2		
27	940600500008		Washer	4		
28	910200200102		Screw	1		

1=整包供货

2=限制供货

3=逐渐停止供货

4=不单件供货

5=见另外表单

01 Hydraulic Components (560846024502,PT20D One-stage) Continuation

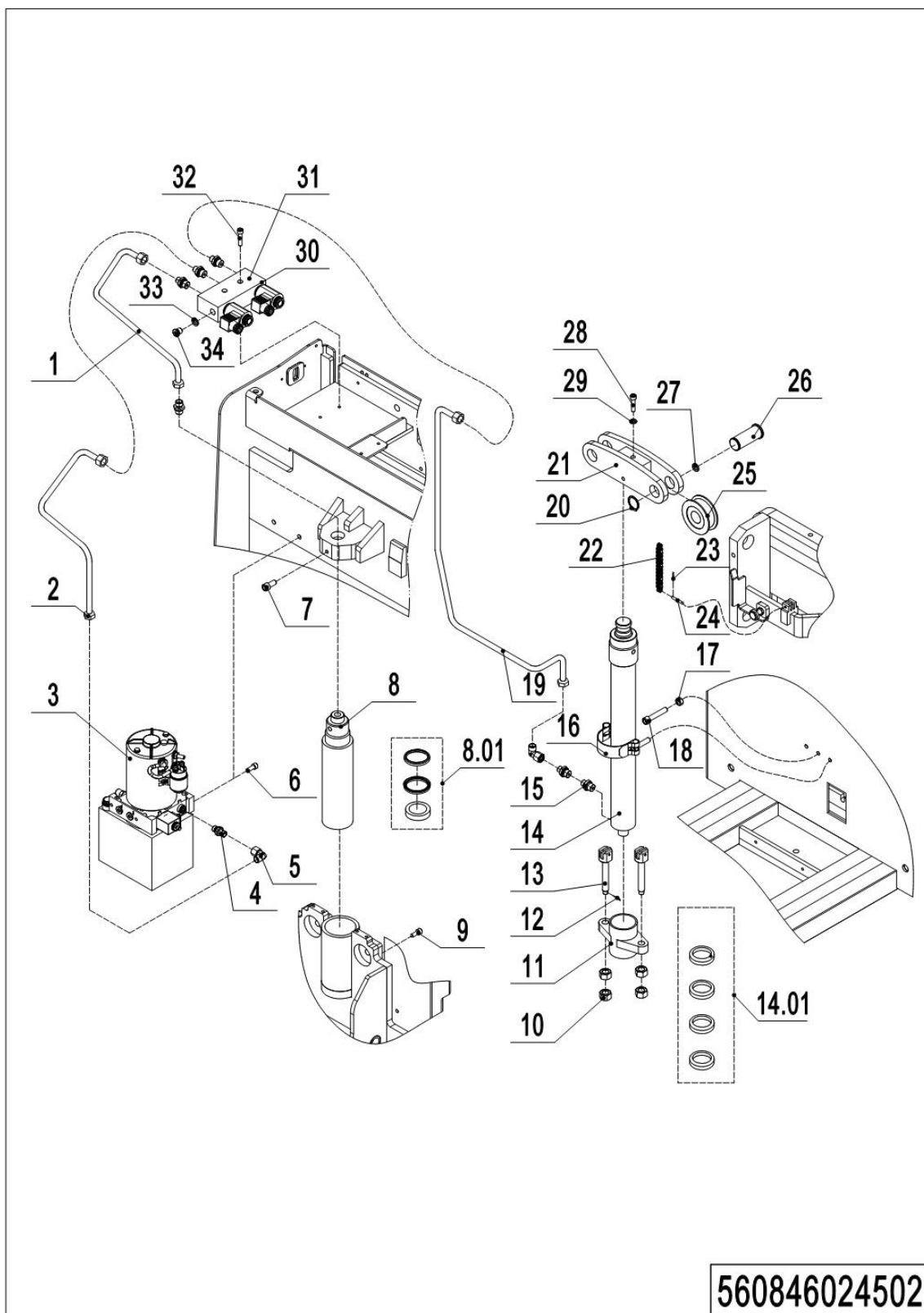

1=整包供货

2=限制供货

3=逐渐停止供货

4=不单件供货

5=见另外表单

01 Hydraulic Components (560846024502,PT20D One-stage) Continuation

No.	Item Code	Mark	Item Description	Qty.	Substitute	Note
29	910400500008		Spring Washer	2		
30	950700200003		Valve	2		
31	560824520003		Valve Block	1		
32	910200200043		Screw	2		
33	910800900005		Bonded Washer	1		
34	911300100001		Screw Plug	1		

02 Hydraulic Components (561146024501,PT20D)

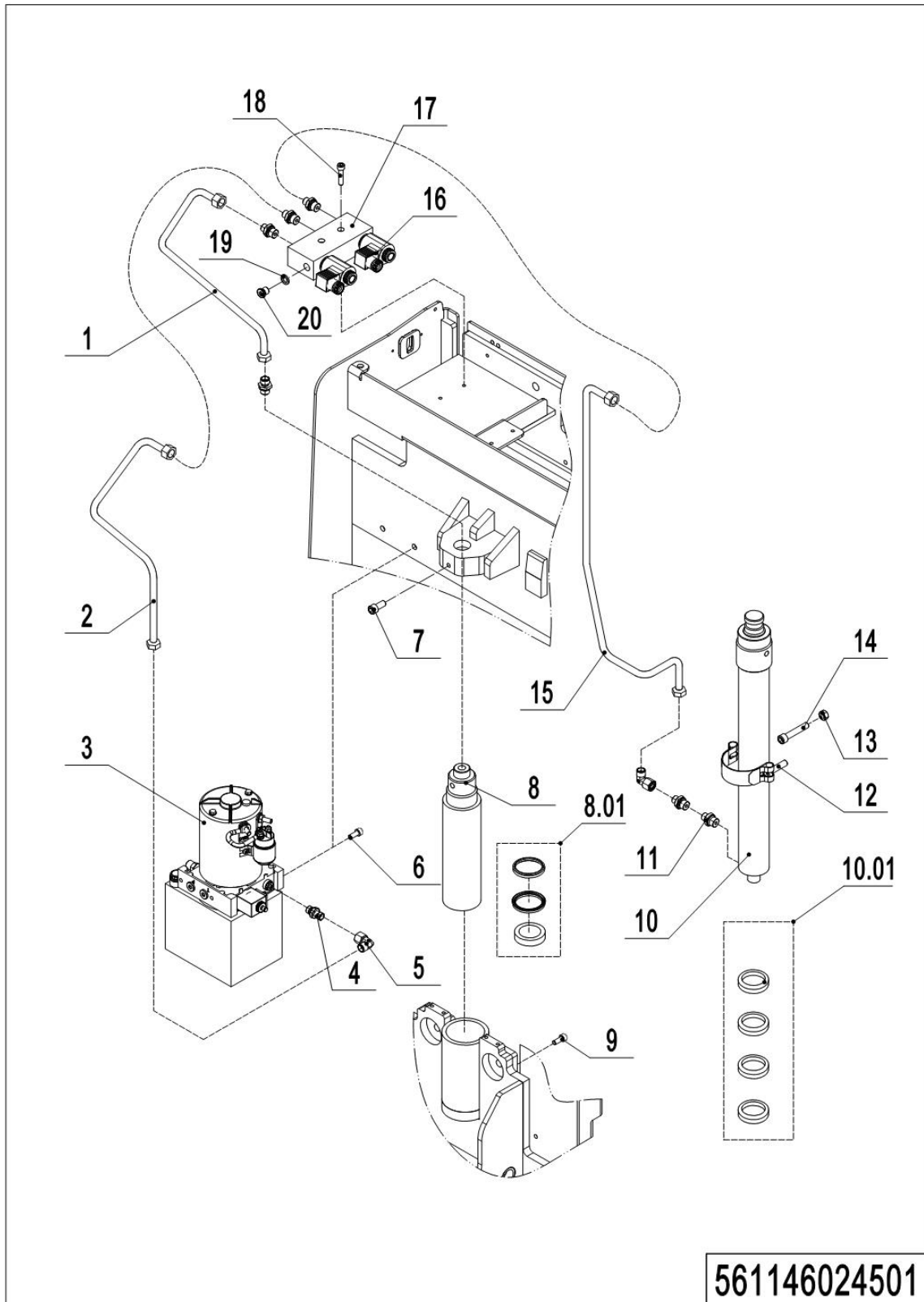

1=整包供货

2=限制供货

3=逐渐停止供货

4=不单件供货

5=见另外表单

02 Hydraulic Components (561146024501,PT20D)

No.	Item Code	Mark	Item Description	Qty.	Substitute	Note
1	560824520001		Steel Tube	1		
2	560824520000		Steel Tube	1		
3	950900100053		Pump Unit	1		
4	950400400003		Joint	6		
5	950400200003		Joint	2		
6	910200200074		Screw	2		
7	910200200055		Screw	1		
8	560824510001		Cylinder	1		
8.01	504498510000		Seal Kit	1		
9	910200200075		Screw	1		
10	561124510000		Cylinder	1		1600
10	561124510001		Cylinder	1		2000
10	561124510002		Cylinder	1		2400
10.01	532098510010		Seal Kit	1		1600/2000
10.01	533298510050		Seal Kit	1		2400
11	950600300001		Safety Valve	1		
12	940800600003		Hoop	1		
13	910300100007		Nut	3		
14	910100300040		Bolt	1		
15	560824520002		Steel Tube	1		
16	950700200003		Valve	2		
17	560824520003		Valve Block	1		
18	910200200043		Screw	2		
19	910800900005		Bonded Washer	1		
20	911300100001		Screw Plug	1		

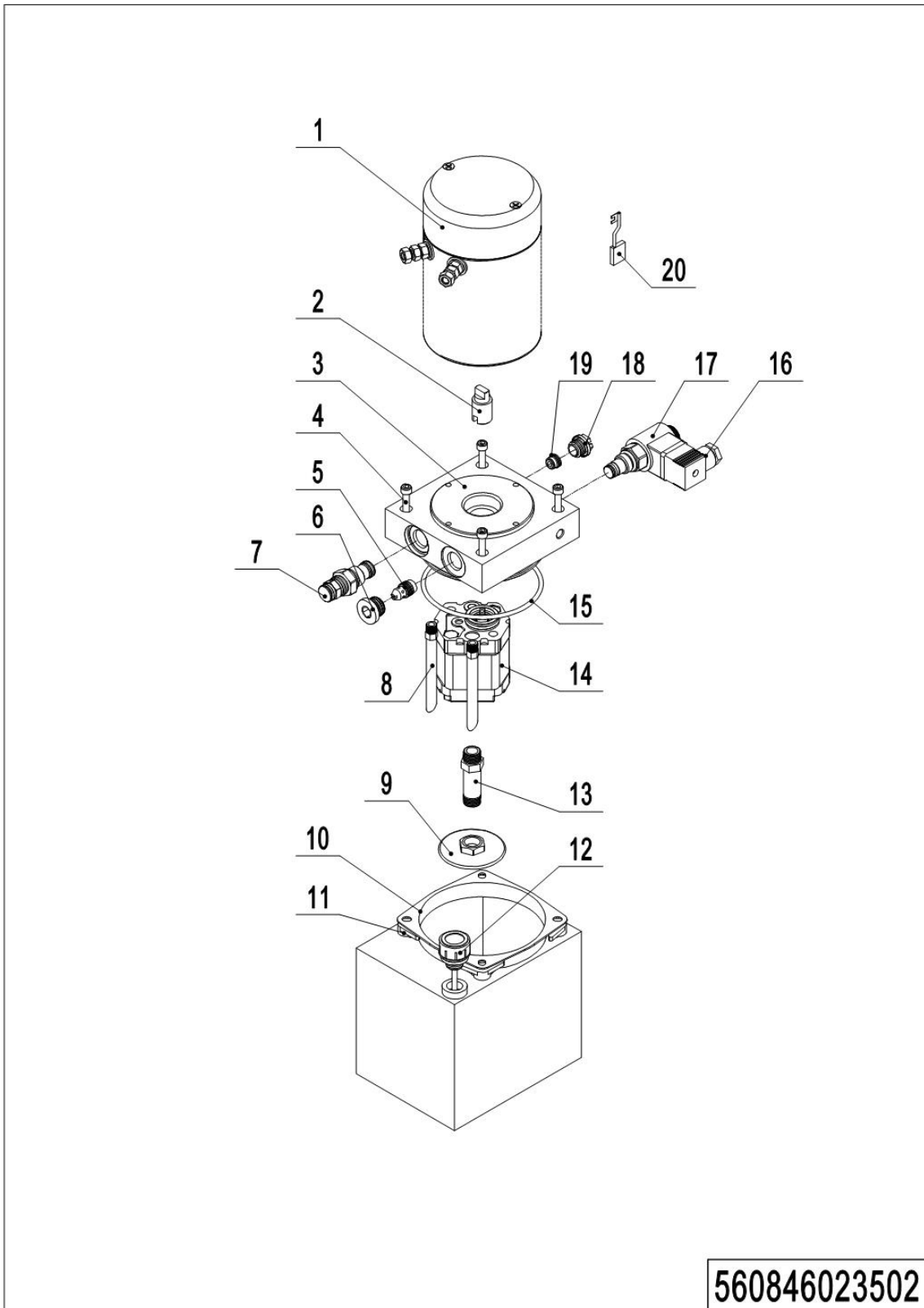
03 Hydraulic Unit (560846023502)

03 Hydraulic Unit (560846023502)

No.	Item Code	Mark	Item Description	Qty.	Substitute	Note
1	560802023503		Motor	1		
2	560898520041		Coupling	1		
3	560898520042		Valve Block	1		
4	910200200040		Screw	4		
5	505798510006		Compensation Valve	1		
6	402698520020		Plug	1		
7	532098510007		Overflow Valve	1		
8	505698520044		Pipe	1		
9	402698520010		Filter	1		
10	560898510012		Tank	1		
11	560898520043		Nut	4		
12	505698520047		Cap-Tank	1		
13	560898520044		Oil Tube	1		
14	532098510000		Gear Pump	1		
15	560898520045		O-Ring	1		
16	505698520055		Coil	1		
17	532098510006		Magnetic Valve	1		
18	505798520015		End Cap	1		
19	505698520038		Check Valve	1		
20	560898520051		Carbon Brush	1		

Chapter 3: Truck Frame

01 Truck Frame (560846021502)

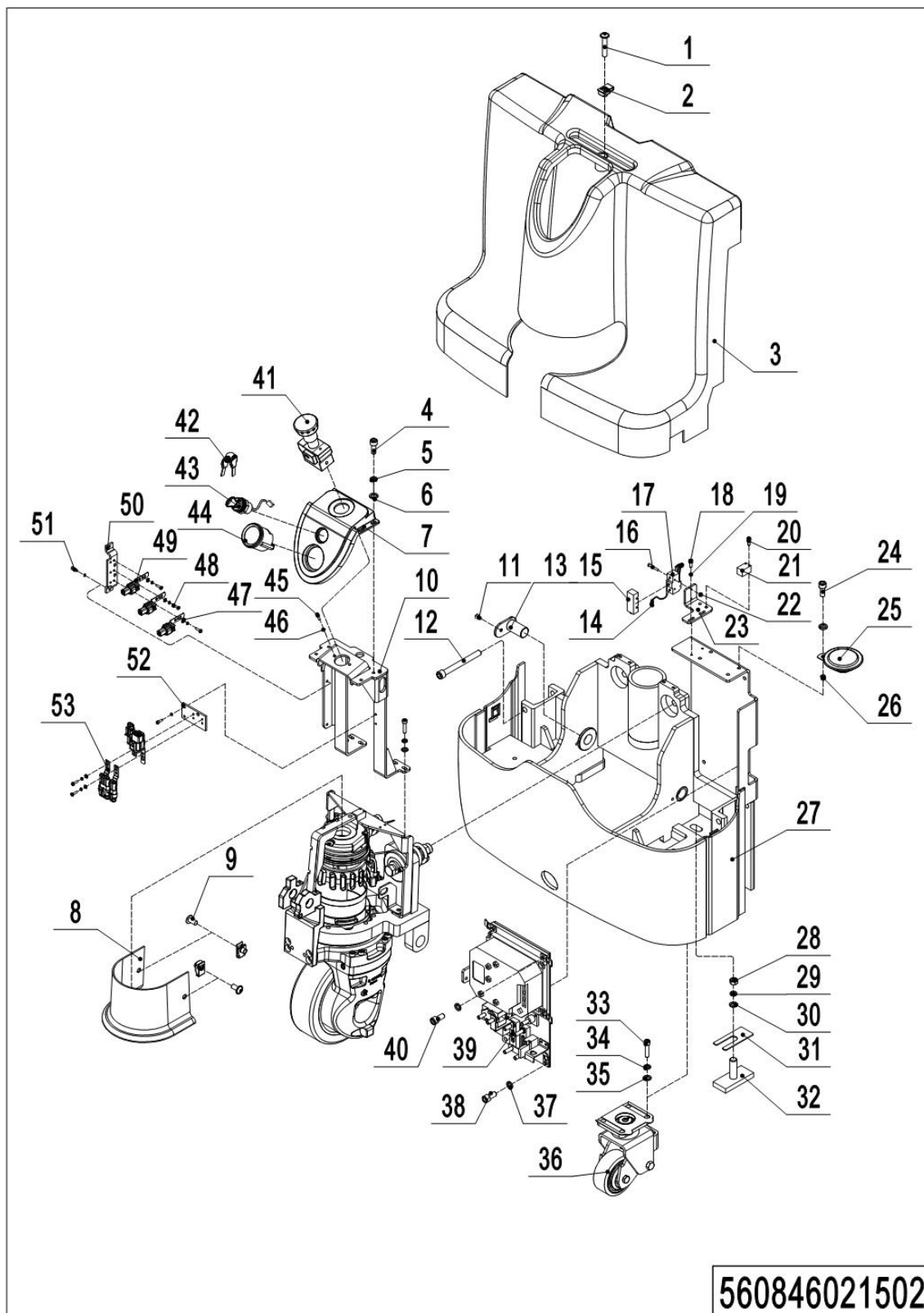

1=整包供货

2=限制供货

3=逐渐停止供货

4=不单件供货

5=见另外表单

01 Truck Frame (560846021502)

No.	Item Code	Mark	Item Description	Qty.	Substitute	Note
1	941100100006		Screw	1		
2	940400400003		Cage Nut	3		
3	505021520003		Protective Cover	1		
4	910200200035		Screw	6		
5	910400500005		Spring Washer	7		
6	910400100005		Flat Washer	6		
7	504410020001		Protective Cover	1		
8	505021520004		Protective Cover	1		
9	941100100007		Screw	2		
10	560821510001		Bracket	1		
11	910200400015		Screw	2		
12	910100100058		Bolt	2		
13	560821510003		Pin	2		
14	504433010002		Wire Harness	1		
15	920200300008		Protective Cover	1		
16	910200500028		Screw	2		
17	920200300003		Microswitch	1		
18	910200200012		Screw	2		
19	910400500003		Spring Washer	12		
20	910200200005		Screw	2		PT20D
21	920200400001		Proximity Switch	1		PT20D
22	910300500001		Nut	2		
23	560821520015		Mounting Plate	1		
24	910200200036		Screw	1		
25	920500100001		Horn	1		
26	910300500003		Nut	1		
27	560821510002		Chassis(560x1150)	1		
28	910300100010		Nut	2		
29	910400500010		Spring Washer	2		
30	910400100010		Flat Washer	2		

1=整包供货

2=限制供货

3=逐渐停止供货

4=不单件供货

5=见另外表单

01 Truck Frame (560846021502) Continuation

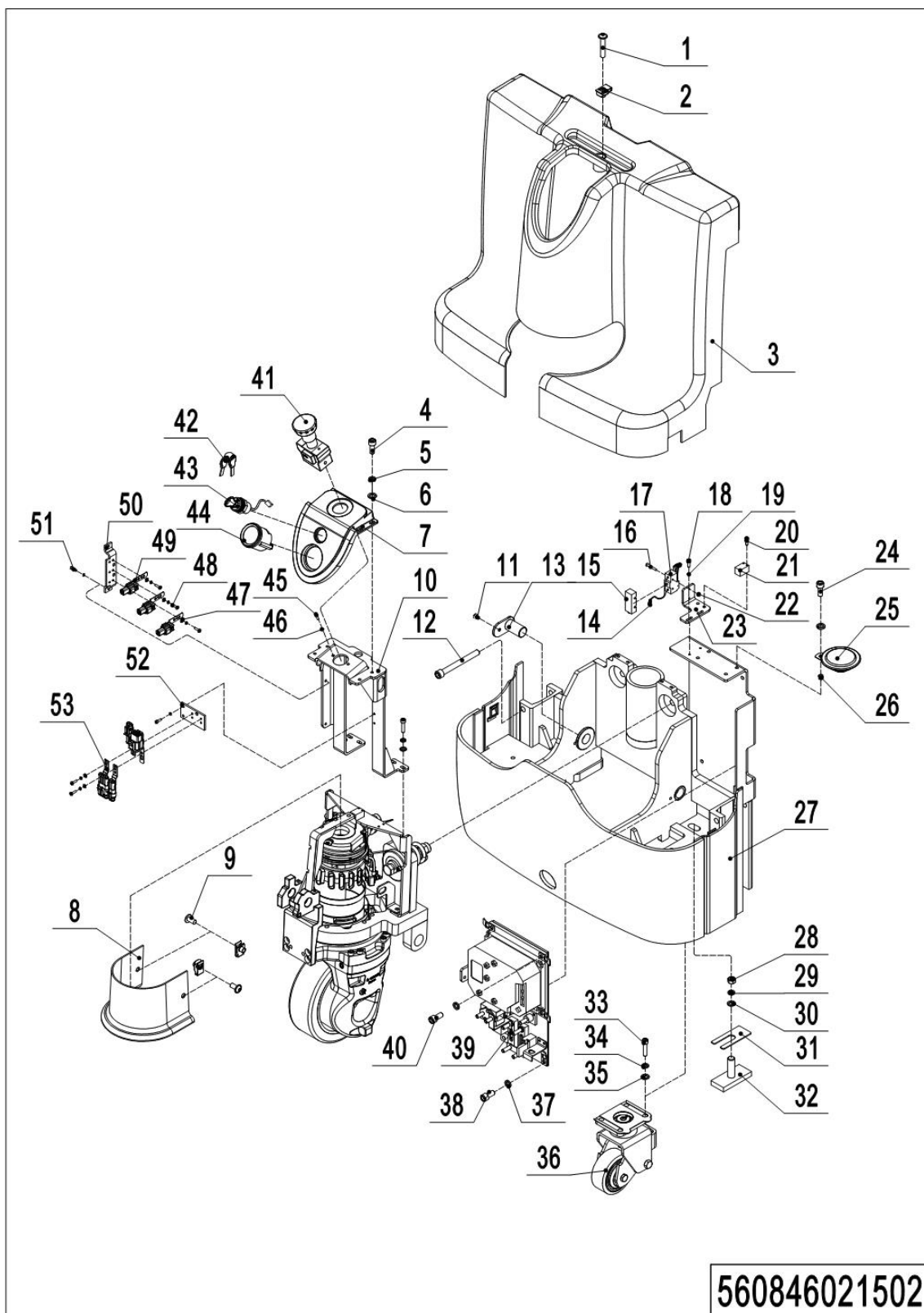

1=整包供货

2=限制供货

3=逐渐停止供货

4=不单件供货

5=见另外表单

01 Truck Frame (560846021502) Continuation

No.	Item Code	Mark	Item Description	Qty.	Substitute	Note
31	560521520022		Subplate	2		
32	560521510002		Adjusting Block	2		
33	910200200078		Screw	8		
34	910400500007		Spring Washer	8		
35	910400100007		Flat Washer	8		
36	560816510000		Caster Assembly	2		
37	910400500006		Spring Washer	4		
38	910200200058		Screw	2		
39	504433010011		Electronic Components	1		
40	910200200059		Screw	2		
41	920200100001	2	Emergency Button	1		
42	505698520031	2	Key	1		
43	505634010000	2	Key Switch	1		
44	921100100012	2	Display	1		
45	910200200023	1	Screw	2		
46	910400500004	1	Spring Washer	2		
47	910400100003	1	Flat Washer	10		
48	910200500022	1	Screw	10		
49	921300300005		Holder	5		
50	504421520023		Bracket	1		
51	910200200014		Screw	4		
52	504421520024		Plate	1		
53	921300300010		Connector Holder	2		

02 Truck Frame (560846021503) (EN1175-2020)

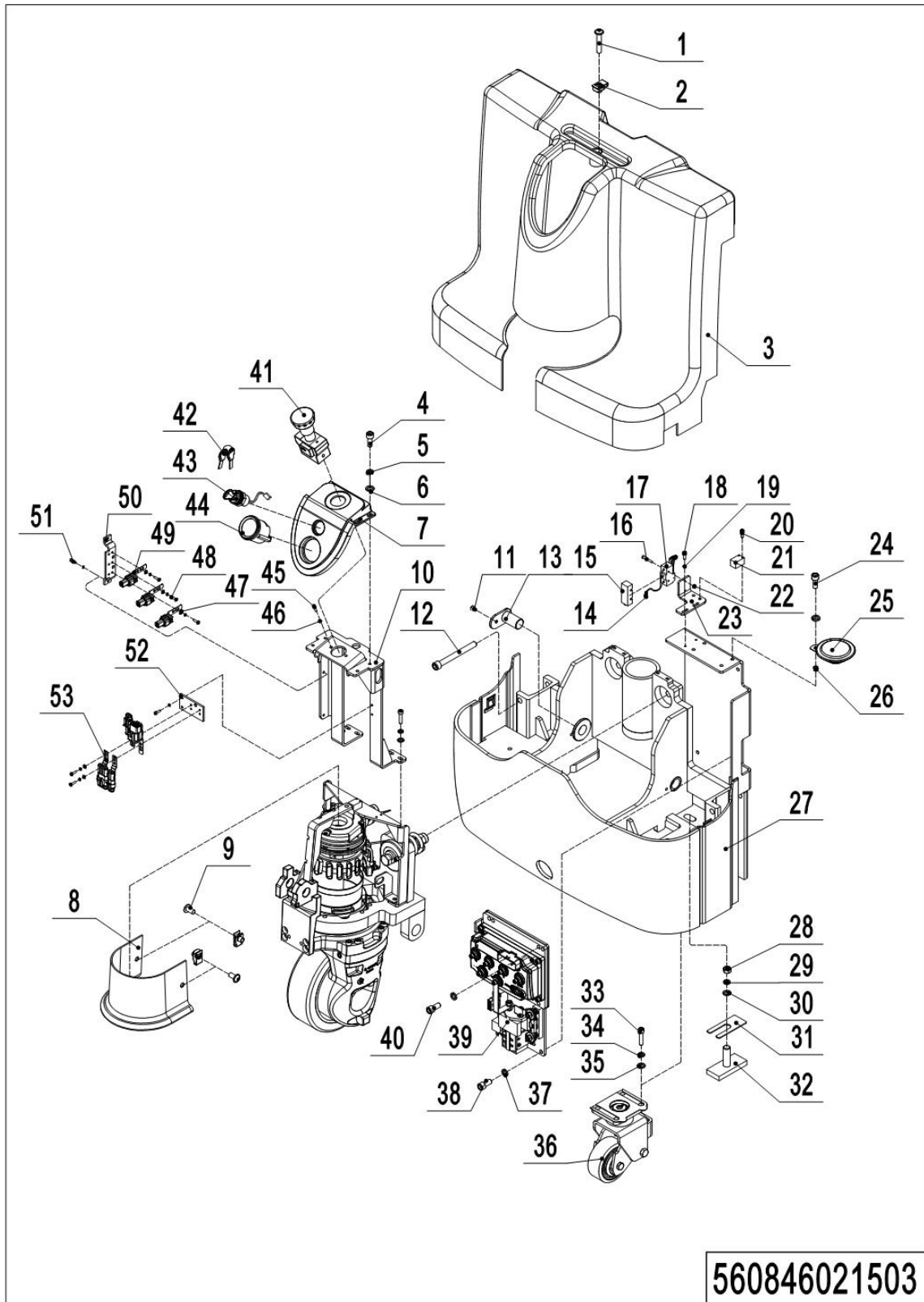

1=整包供货

2=限制供货

3=逐渐停止供货

4=不单件供货

5=见另外表单

02 Truck Frame (560846021503)(EN1175-2020)

No.	Item Code	Mark	Item Description	Qty.	Substitute	Note
1	941100100006		Screw	1		
2	940400400003		Cage Nut	3		
3	505021520003		Protective Cover	1		
4	910200200035		Screw	6		
5	910400500005		Spring Washer	7		
6	910400100005		Flat Washer	6		
7	504410020001		Protective Cover	1		
8	505021520004		Protective Cover	1		
9	941100100007		Screw	2		
10	560821510001		Bracket	1		
11	910200400015		Screw	2		
12	910100100058		Bolt	2		
13	560821510003		Pin	2		
14	504433010002		Wire Harness	1		
15	920200300008		Protective Cover	1		
16	910200500028		Screw	2		
17	920200300003		Microswitch	1		
18	910200200012		Screw	2		
19	910400500003		Spring Washer	12		
20	910200200005		Screw	2		PT20D Three-stage
21	920200400001		Proximity Switch	1		PT20D Three-stage
22	910300500001		Nut	2		
23	560821520015		Mounting Plate	1		
24	910200200036		Screw	1		
25	920500100001		Horn	1		
26	910300500003		Nut	1		
27	560821510002		Chassis(560x1150)	1		
28	910300100010		Nut	2		
29	910400500010		Spring Washer	2		
30	910400100010		Flat Washer	2		

1=整包供货

2=限制供货

3=逐渐停止供货

4=不单件供货

5=见另外表单

02 Truck Frame (560846021503) (EN1175-2020)Continuation

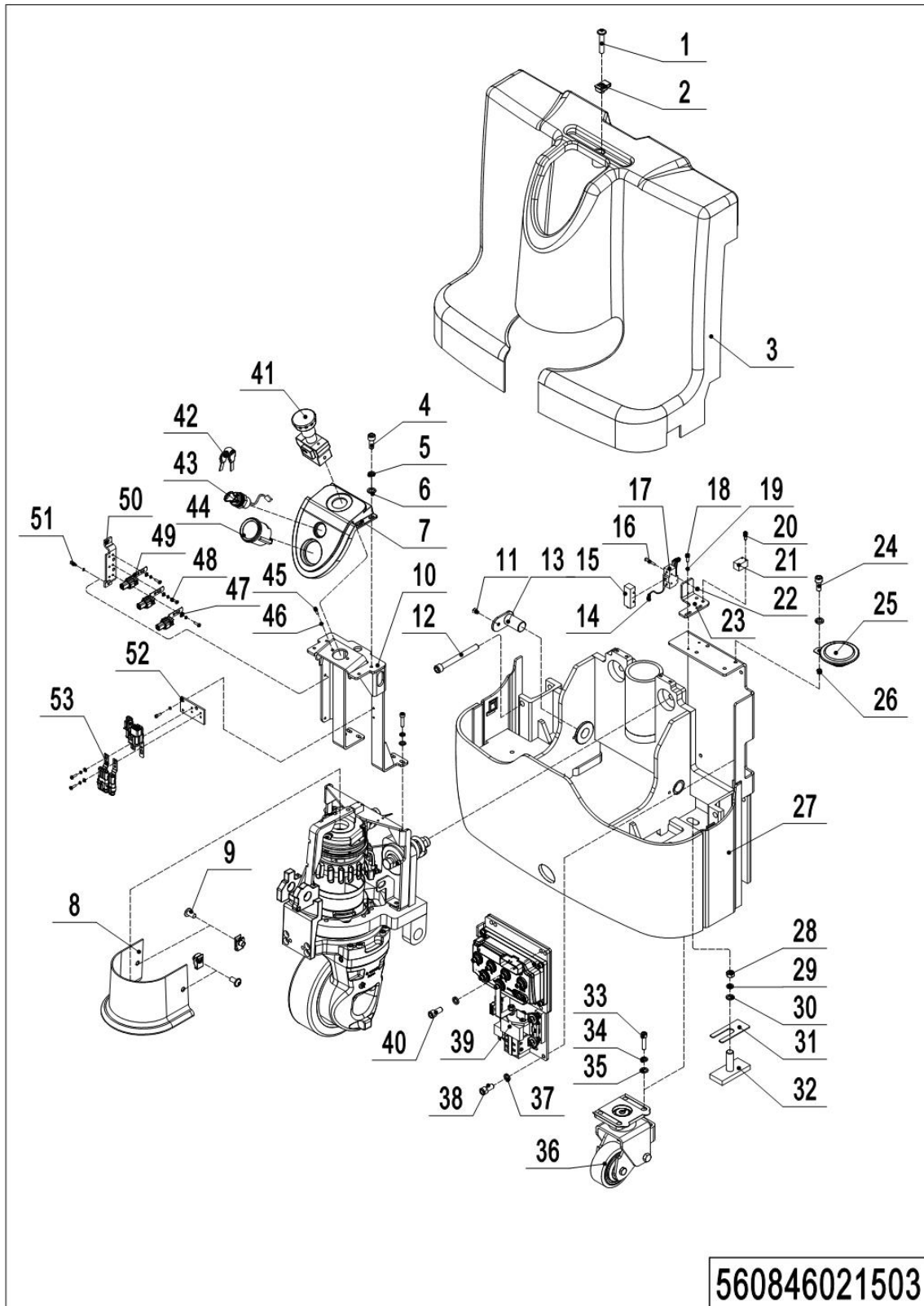

1=整包供货

2=限制供货

3=逐渐停止供货

4=不单件供货

5=见另外表单

02 Truck Frame (560846021503) (EN1175-2020)Continuation

No.	Item Code	Mark	Item Description	Qty.	Substitute	Note
31	560521520022		Gasket	2		
32	560521510002		Adjusting Block	2		
33	910200200078		Screw	8		
34	910400500007		Spring Washer	8		
35	910400100007		Flat Washer	8		
36	560816510000		Caster Assembly	2		
37	910400500006		Spring Washer	4		
38	910200200058		Screw	2		
39	560833010038		Electronic Components	1		
40	910200200059		Screw	2		
41	920200100001	2	Emergency Button	1		
42	505698520031	2	Key	1		
43	505634010000	2	Key Switch	1		
43	505634010001		Key Switch	1		Li
44	921100100135	2	Display	1		
45	910200200023	1	Screw	2		
46	910400500004	1	Spring Washer	2		
47	910400100003	1	Flat Washer	10		
48	910200500022	1	Screw	10		
49	921300300005		Holder	5		
50	504421520023		Bracket	1		
51	910200200014		Screw	4		
52	504421520024		Plate	1		
53	921300300010		Connector Holder	2		

Chapter 4: Chassis

01 Chassis (560846038502,PT20D One-stage)

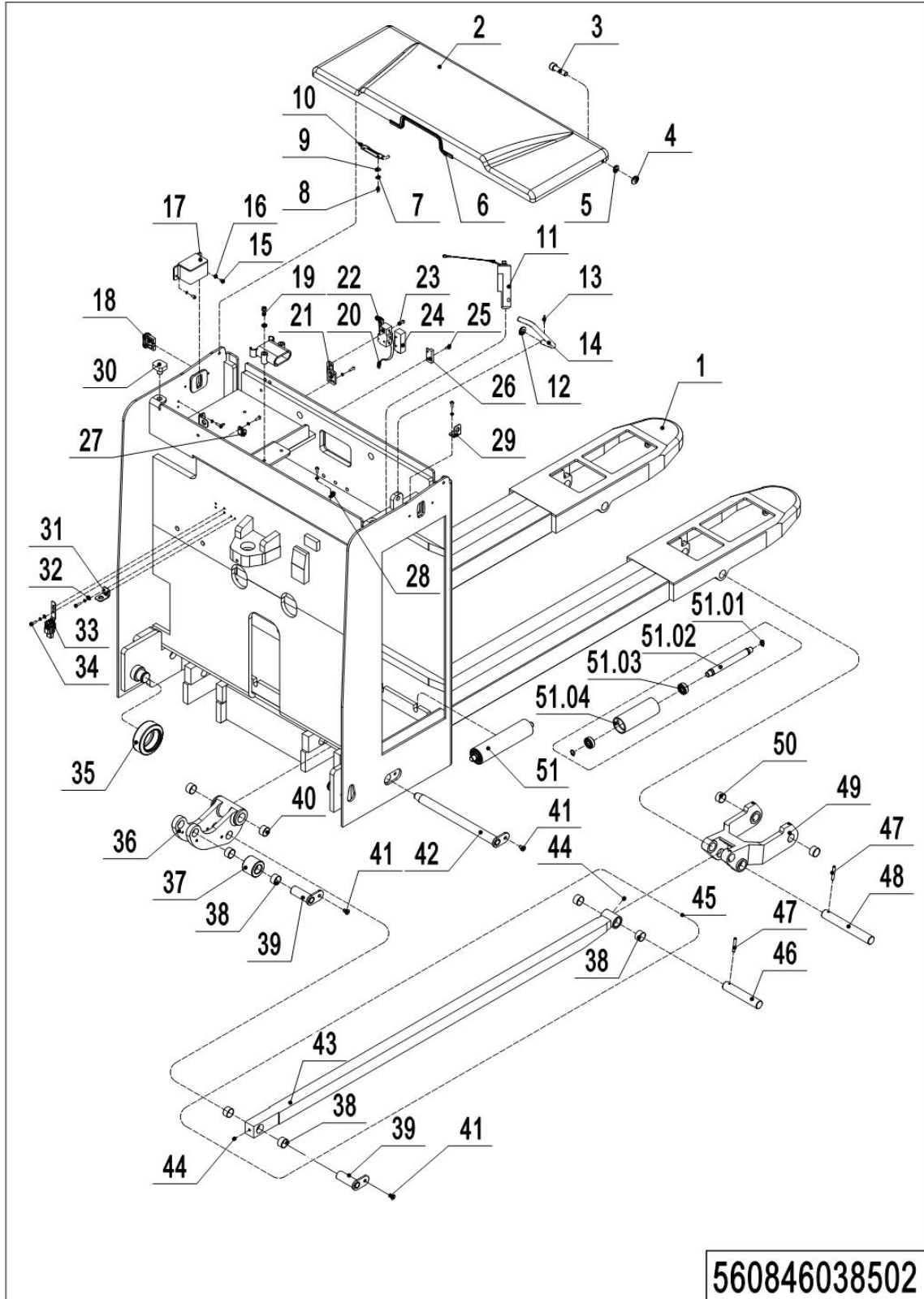

1=整包供货

2=限制供货

3=逐渐停止供货

4=不单件供货

5=见另外表单

01 Chassis (560846038502,PT20D One-stage)

No.	Item Code	Mark	Item Description	Qty.	Substitute	Note
1	560838510000		Chassis(560x1150,210Ah)	1		
2	560821010000		Cell Cover	1		
3	910200200024		Screw	1		
4	910400100004		Flat Washer	1		
5	910400500004		Spring Washer	1		
6	505921020007		Sealing Strip	1		
7	910400500003		Spring Washer	2		
8	910200200013		Screw	2		
9	910400100003		Flat Washer	2		
10	940800900001		Lock Pin	1		
11	560838510001		Axle Kit	1		
12	910400100007		Flat Washer	4		
13	910600600030		Cotter Pin	4		
14	560838520036		Support Rod	1		
15	910200500034		Screw	12		
16	910400500003		Spring Washer	16		
17	560838510003		Protective Cover	2		
18	920200800004		Rocker Switch	2		
19	910200200039		Screw	2		
20	560833010013		Wire Harness	1		
21	560838520041		Mounting Plate	1		
22	920200300003		Microswitch	1		
23	910200500028		Screw	2		
24	920200300008		Protective Cover	1		
25	910200500010		Screw	2		
26	532633510000		Switch	1		
27	921300200003		Cable Clamp	1		
28	921300200001		Cable Clamp	2		
29	921300300003		Holder	2		
30	505938520016		Crash Pad	2		

1=整包供货

2=限制供货

3=逐渐停止供货

4=不单件供货

5=见另外表单

01 Chassis (560846038502,PT20D One-stage) Continuation

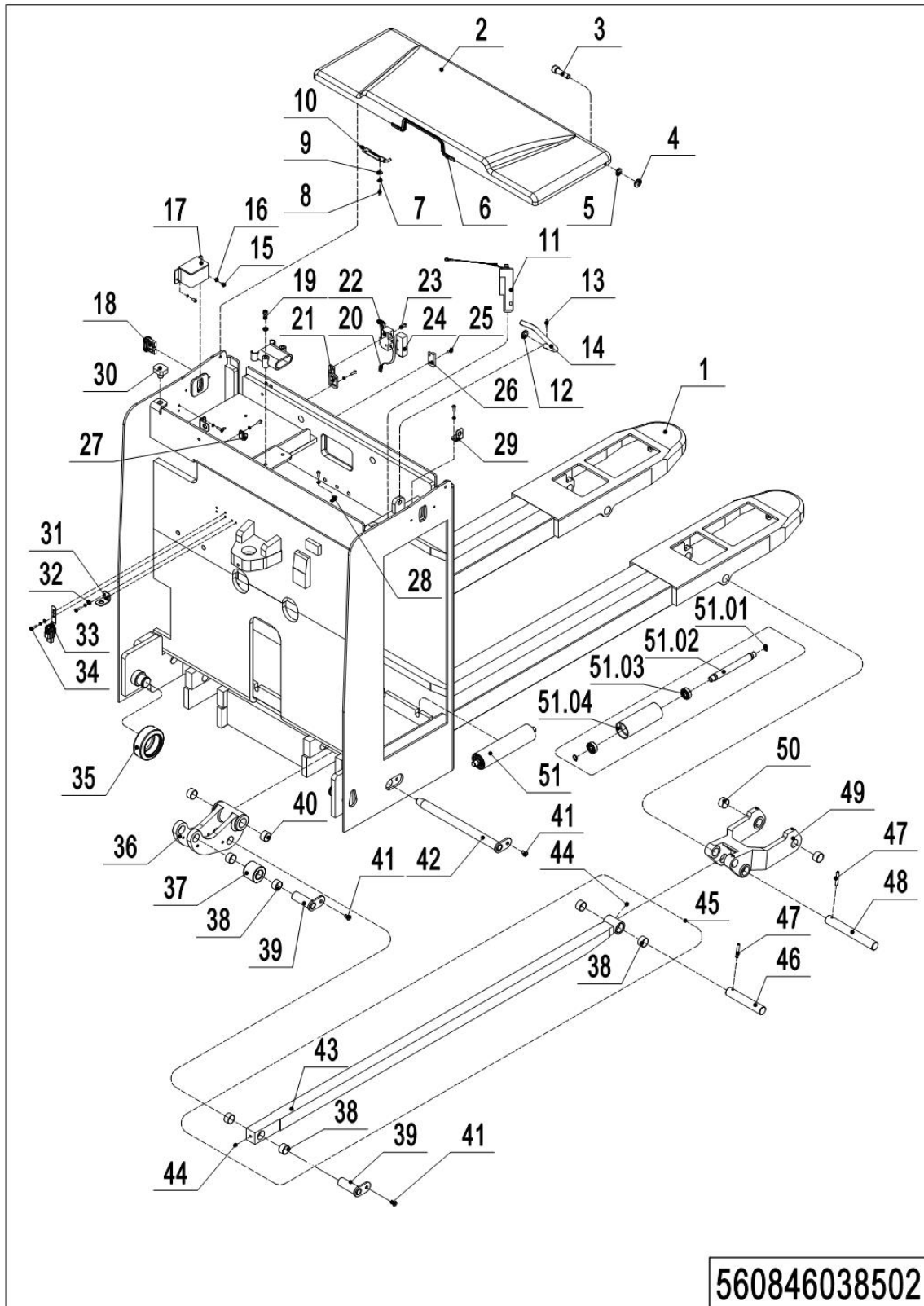

1=整包供货

2=限制供货

3=逐渐停止供货

4=不单件供货

5=见另外表单

01 Chassis (560846038502,PT20D One-stage) Continuation

No.	Item Code	Mark	Item Description	Qty.	Substitute	Note
31	921300300002		Holder	1		
32	910400100003		Flat Washer	6		
33	921300300005		Holder	2		
34	910200500022		Screw	4		
35	940200300001		Compound Roller	2		
36	560543520045		Rib Plate	2		
37	565938520023		Roller	2		
38	940500100012		Bushing	16		
39	565938510003		Pin	4		
40	940500100017		Bushing	4		
41	941100300001		Screw	6		
42	560838510004		Pin	2		
43	560838510002		Push Rod	2		
44	911200100001		Oil Cup	8		
45	560898510000		Push Rod Kit	2		
46	560543520042		Axle	2		
47	910600400027		Spring Pin	4		
48	560543520041		Pin	2		
49	560543520040		Riser	2		
50	940500200005		Bushing	4		
51	505638510028		Roller	6		
51.01	910401300006		Circlip	12		
51.02	505638520119		Axle	6		
51.03	910700200017		Bearing	12		
51.04	505638520120		Roller	6		

02 Chassis (560846038503,PT20D One-stage) (EN1175-2020)

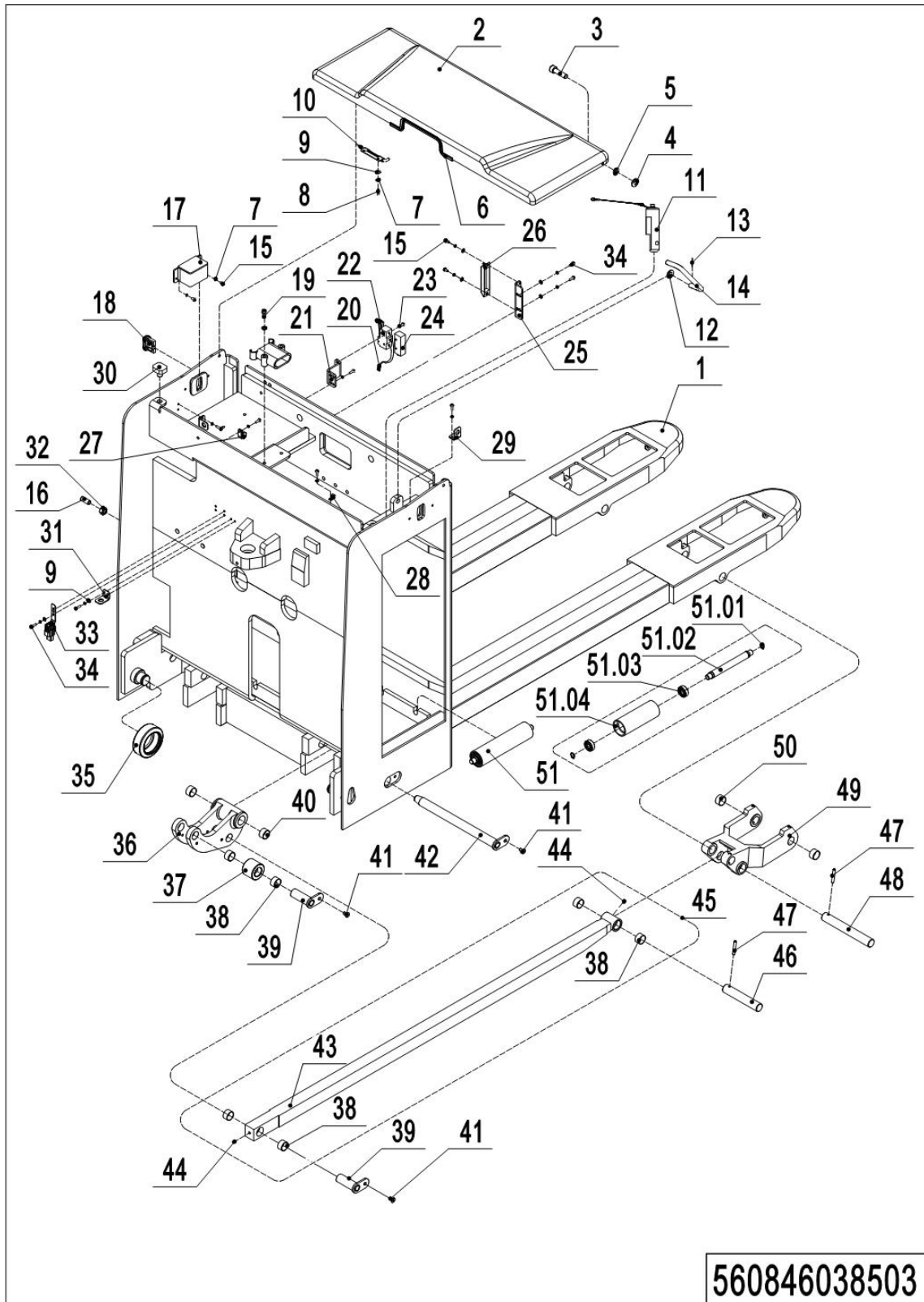

1=整包供货

2=限制供货

3=逐渐停止供货

4=不单件供货

5=见另外表单

02Chassis (560846038503,PT20D) (EN1175-2020)

No.	Item Code	Mark	Item Description	Qty.	Substitute	Note
1	560838510012		Chassis(560x1150,210Ah)	1		
2	560821010000		Cell Cover	1		
3	910200200024		Screw	1		
4	910400100004		Flat Washer	1		
5	910400500004		Spring Washer	1		
6	505921020007		Sealing Strip	1		
7	910400500003		Spring Washer	22		
8	910200200013		Screw	2		
9	910400100003		Flat Washer	12		
10	940800900001		Lock Pin	1		
11	560838510001		Axle Kit	1		
12	910400100007		Flat Washer	4		
13	910600600030		Cotter Pin	4		
14	560838520036		Support Rod	1		
15	910200500034		Screw	14		
16	910200800028		Screw	1		
17	560838510003		Protective Cover	2		
18	920200800004		Rocker Switch	2		
19	910200200039		Screw	2		
20	560833010013		Wire Harness	1		
21	560838520041		Mounting Plate	1		
22	920200300003		Microswitch	1		
23	910200500028		Screw	2		
24	920200300008		Protective Cover	1		
25	560838520042		Mounting Plate	1		
26	560833010029		Switch	1		
27	921300200003		Cable Clamp	1		
28	921300200001		Cable Clamp	2		
29	921300300003		Holder	2		
30	505938520016		Crash Pad	2		

02 Chassis (560846038503,PT20D One-stage) (EN1175-2020)Continuation

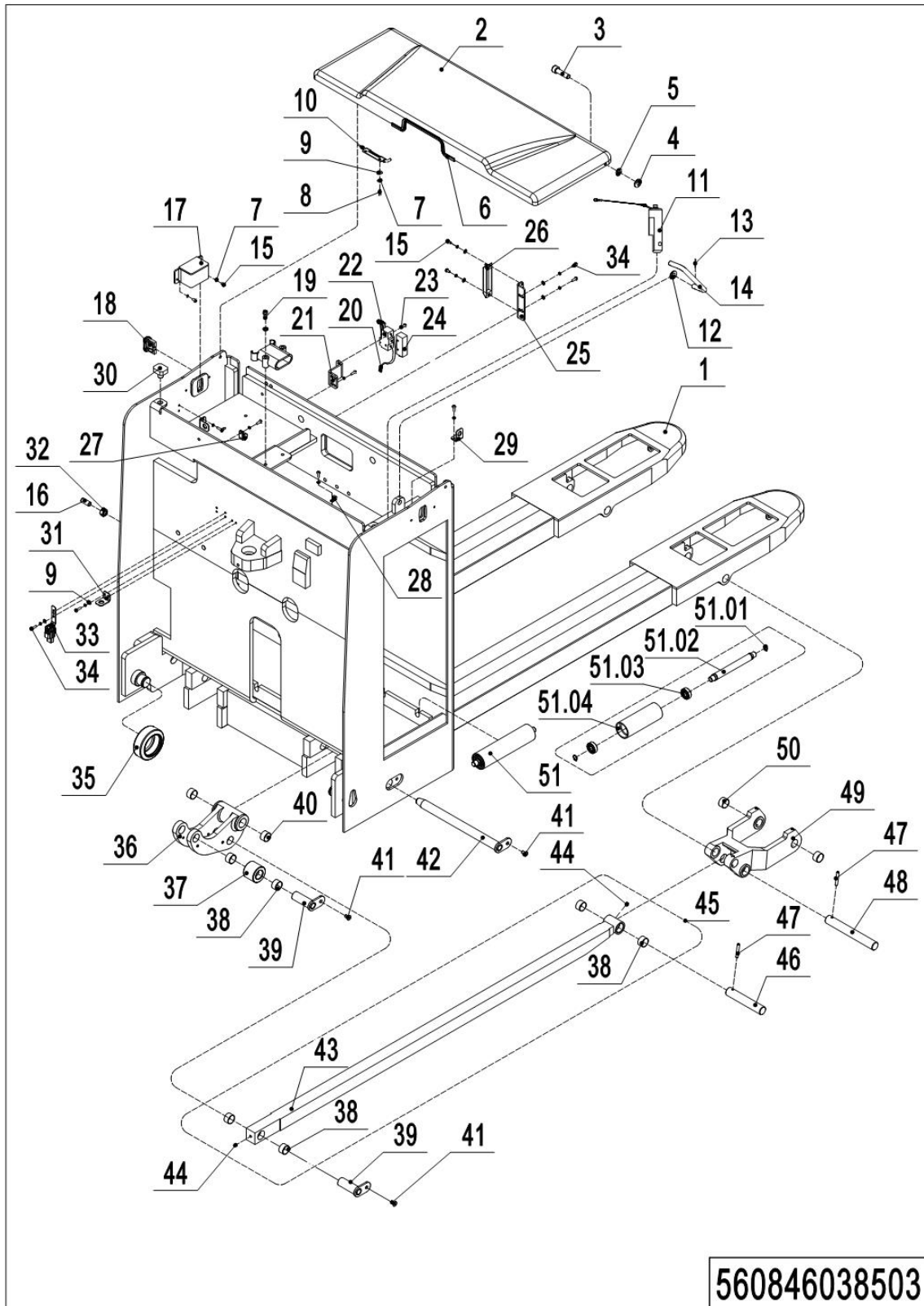

1=整包供货

2=限制供货

3=逐渐停止供货

4=不单件供货

5=见另外表单

02Chassis (560846038503,PT20D One-stage) (EN1175-2020) Continuation

No.	Item Code	Mark	Item Description	Qty.	Substitute	Note
31	921300300002		Holder	1		
32	910300100007		Nut	1		
33	921300300005		Holder	2		
34	910200500022		Screw	6		
35	940200300001		Compound Roller	2		
36	560543520045		Rib Plate	2		
37	565938520023		Roller	2		
38	940500100012		Bushing	16		
39	565938510003		Pin	4		
40	940500100017		Bushing	4		
41	941100300001		Screw	6		
42	560838510004		Pin	2		
43	560838510002		Push Rod	2		
44	911200100001		Oil Cup	8		
45	560898510000		Push Rod Kit	2		
46	560543520042		Axle	2		
47	910600400027		Spring Pin	4		
48	560543520041		Pin	2		
49	560543520040		Riser	2		
50	940500200005		Bushing	4		
51	505638510028		Roller	6		
51.01	910401300006		Circlip	12		
51.02	505638520119		Axle	6		
51.03	910700200017		Bearing	12		
51.04	505638520120		Roller	6		

03 Chassis (561146038501,PT20D)

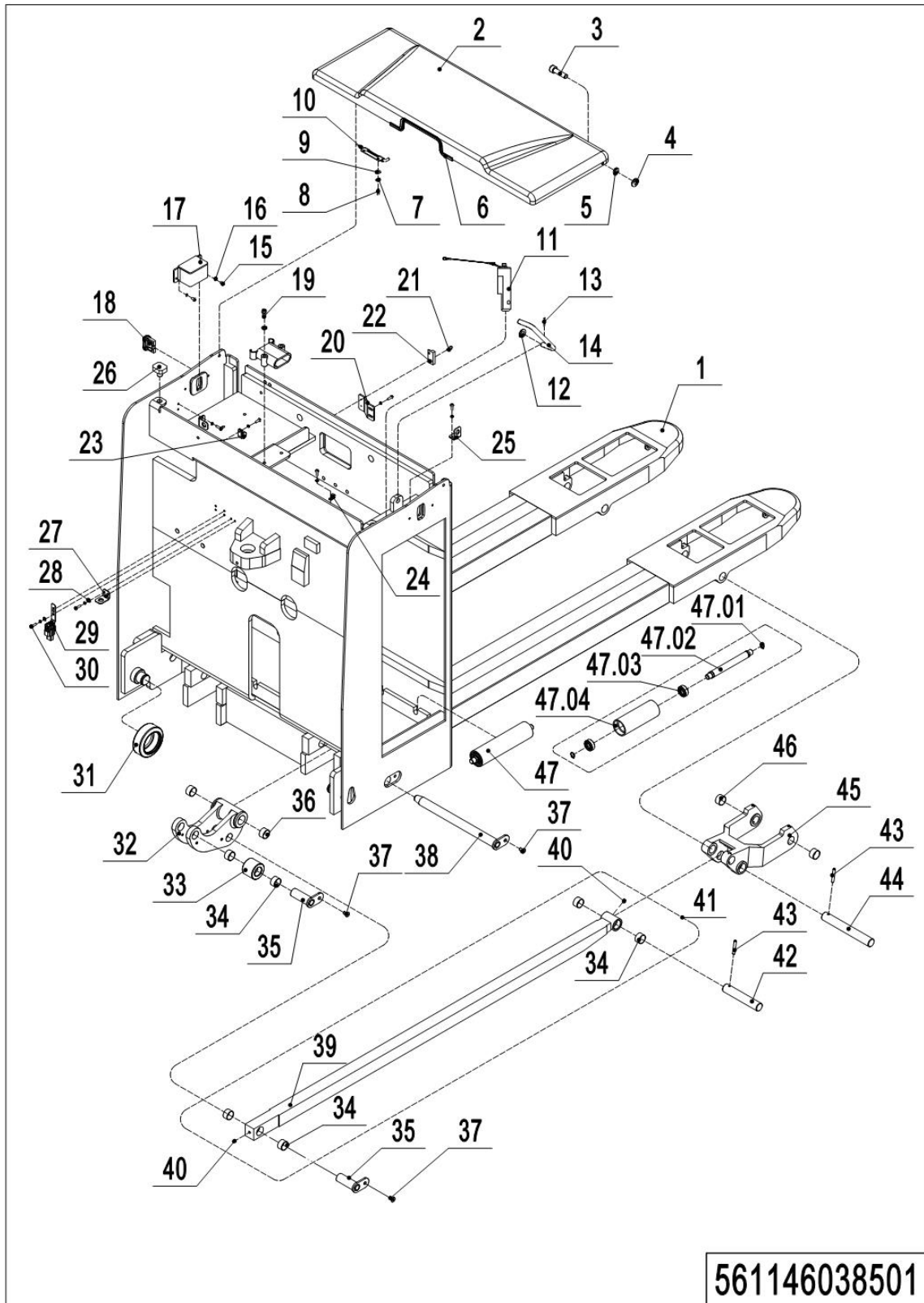

1=整包供货

2=限制供货

3=逐渐停止供货

4=不单件供货

5=见另外表单

03Chassis(561146038501,PT20D)

No.	Item Code	Mark	Item Description	Qty.	Substitute	Note
1	560838510000		Chassis(560x1150,210Ah)	1		
2	560821010000		Cell Cover	1		
3	910200200024		Screw	1		
4	910400100004		Flat Washer	1		
5	910400500004		Spring Washer	1		
6	505921020007		Sealing Strip	1		
7	910400500003		Spring Washer	2		
8	910200200013		Screw	2		
9	910400100003		Flat Washer	2		
10	940800900001		Lock Pin	1		
11	560838510001		Axle Kit	1		
12	910400100007		Flat Washer	4		
13	910600600030		Cotter Pin	4		
14	560838520036		Support Rod	1		
15	910200500034		Screw	12		
16	910400500003		Spring Washer	16		
17	560838510003		Protective Cover	2		
18	920200800004		Rocker Switch	2		
19	910200200039		Screw	2		
20	561138520000		Fixing Plate	1		Three-stage
21	910200500010		Screw	2		Three-stage
22	532633510000		Switch	1		Three-stage
23	921300200003		Cable Clamp	1		
24	921300200001		Cable Clamp	2		
25	921300300003		Holder	2		
26	505938520016		Crash Pad	2		
27	921300300002		Holder	1		
28	910400100003		Flat Washer	6		
29	921300300005		Holder	2		
30	910200500022		Screw	4		

03 Chassis (561146038501,PT20D) Continuation

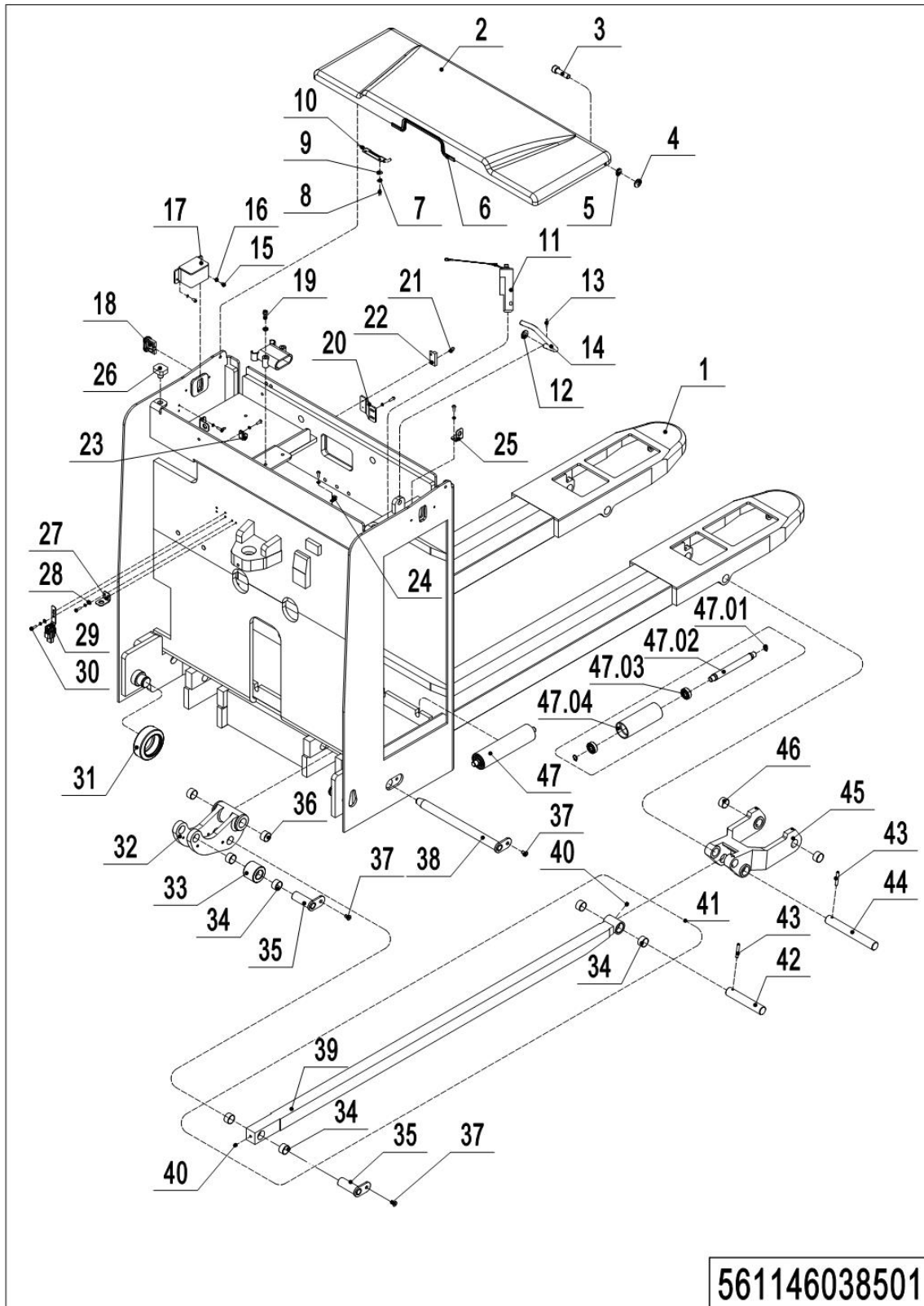

1=整包供货

2=限制供货

3=逐渐停止供货

4=不单件供货

5=见另外表单

03Chassis (561146038501,PT20D) Continuation

No.	Item Code	Mark	Item Description	Qty.	Substitute	Note
31	940200300001		Compound Roller	2		
32	560543520045		Rib Plate	2		
33	565938520023		Roller	2		
34	940500100012		Bushing	16		
35	565938510003		Pin	4		
36	940500100017		Bushing	4		
37	941100300001		Screw	6		
38	560838510004		Pin	2		
39	560838510002		Push Rod	2		
40	911200100001		Oil Cup	8		
41	560898510000		Push Rod Kit	2		
42	560543520042		Axle	2		
43	910600400027		Spring Pin	4		
44	560543520041		Pin	2		
45	560543520040		Riser	2		
46	940500200005		Bushing	4		
47	505638510028		Roller	6		
47.01	910401300006		Circlip	12		
47.02	505638520119		Axle	6		
47.03	910700200017		Bearing	12		
47.04	505638520120		Roller	6		

04 Chassis (561146038502,PT20D) (EN1175-2020)

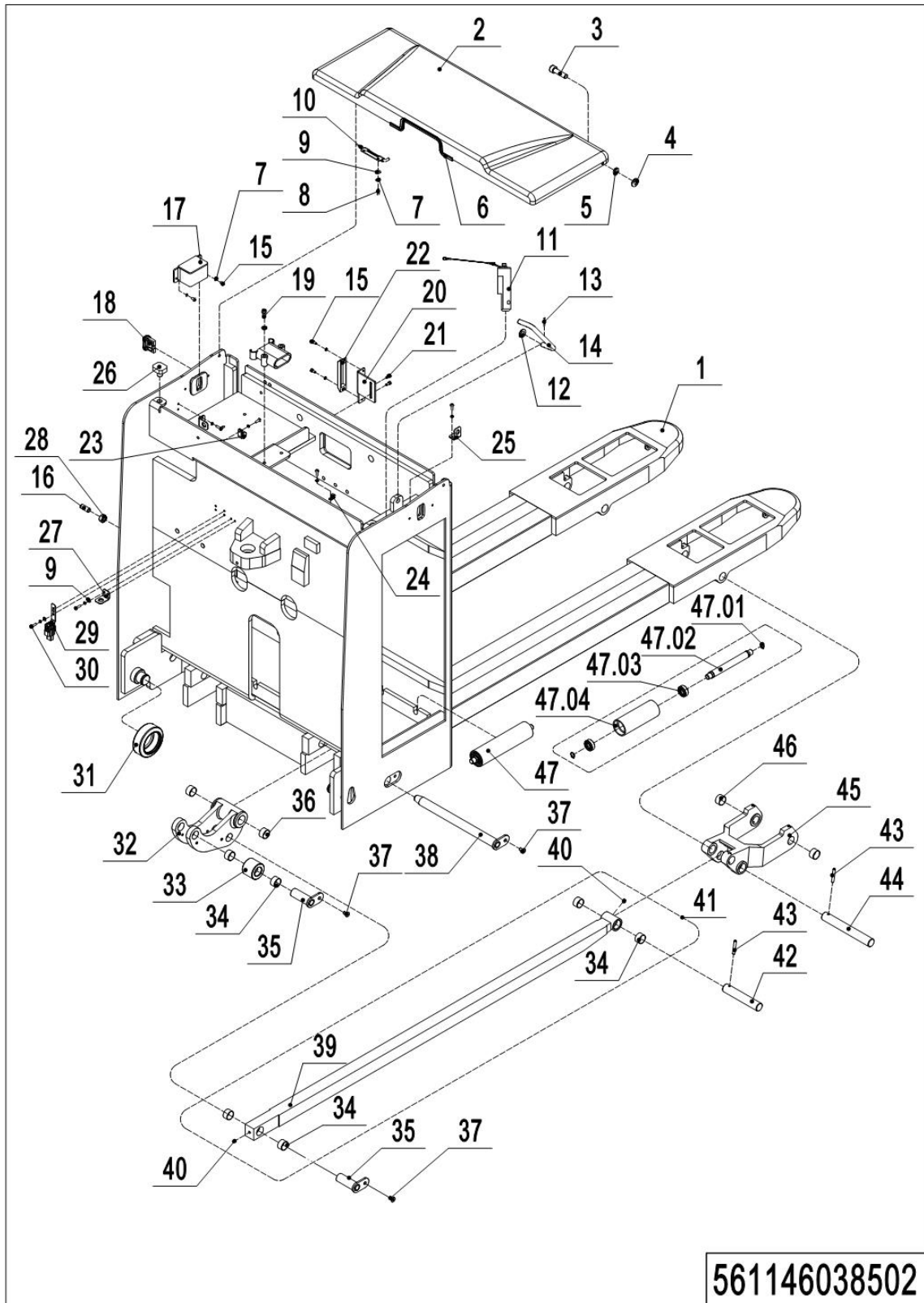

1=整包供货

2=限制供货

3=逐渐停止供货

4=不单件供货

5=见另外表单

04 Chassis(561146038502,PT20D) (EN1175-2020)

No.	Item Code	Mark	Item Description	Qty.	Substitute	Note
1	560838510000		Chassis(560x1150,210Ah)	1		
2	560821010000		Cell Cover	1		
3	910200200024		Screw	1		
4	910400100004		Flat Washer	1		
5	910400500004		Spring Washer	1		
6	505921020007		Sealing Strip	1		
7	910400500003		Spring Washer	20		
8	910200200013		Screw	2		
9	910400100003		Flat Washer	8		
10	940800900001		Lock Pin	1		
11	560838510001		Axle Kit	1		
12	910400100007		Flat Washer	4		
13	910600600030		Cotter Pin	4		
14	560838520036		Support Rod	1		
15	910200500034		Screw	14		
16	910200800028		Screw	1		
17	560838510003		Protective Cover	2		
18	920200800004		Rocker Switch	2		
19	910200200039		Screw	2		
20	561138520001		Mounting Plate	1		Three-stage
21	910200500010		Screw	2		Three-stage
22	560833010029		Switch	1		Three-stage
23	921300200003		Cable Clamp	1		
24	921300200001		Cable Clamp	2		
25	921300300003		Holder	2		
26	505938520016		Crash Pad	2		
27	921300300002		Holder	1		
28	910300100007		Nut	1		
29	921300300005		Holder	2		
30	910200500022		Screw	4		

04 Chassis (561146038502,PT20D) (EN1175-2020) Continuation

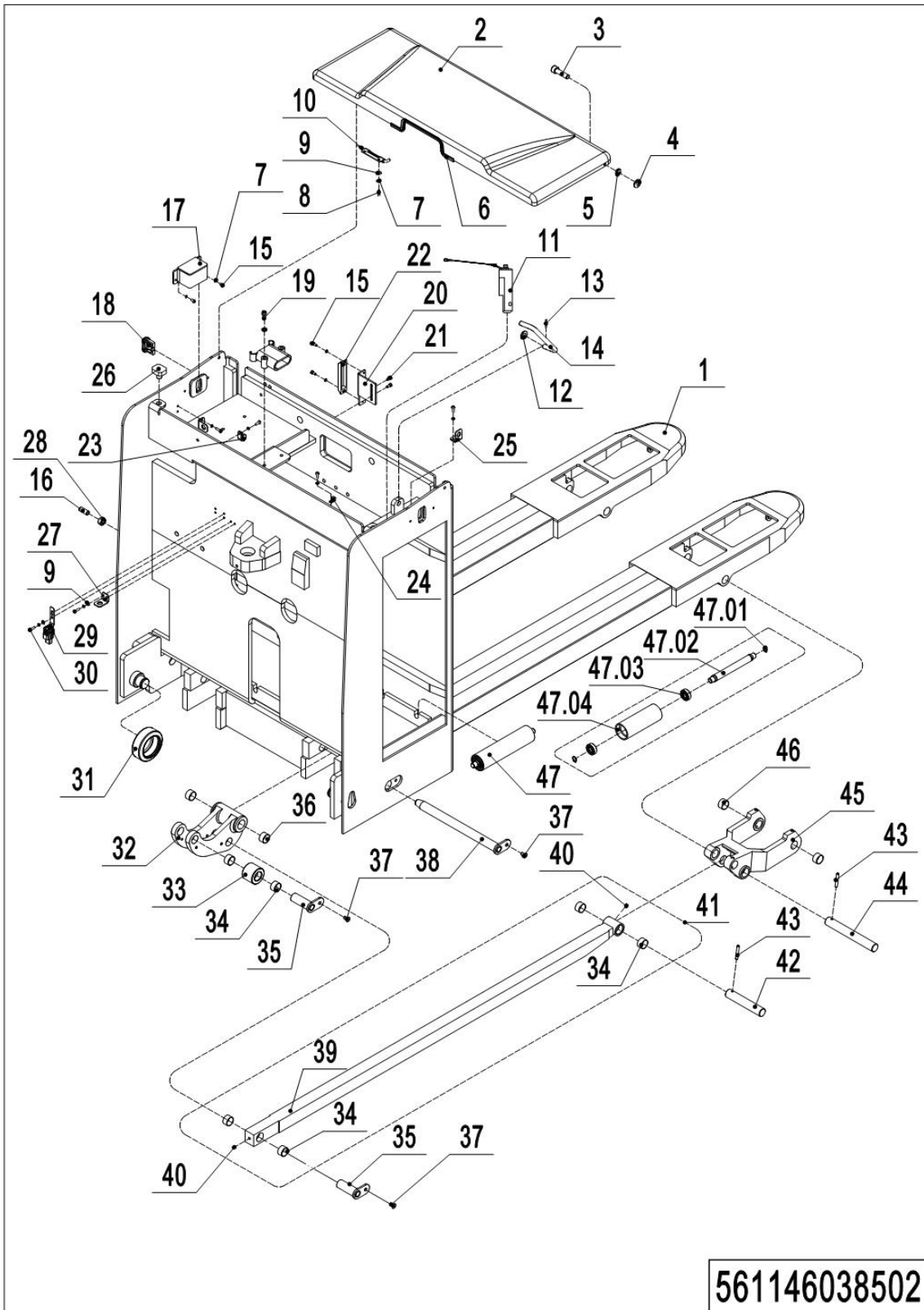

1=整包供货

2=限制供货

3=逐渐停止供货

4=不单件供货

5=见另外表单

05Chassis (561146038502,PT20D) (EN1175-2020) Continuation

No.	Item Code	Mark	Item Description	Qty.	Substitute	Note
31	940200300001		Compound Roller	2		
32	560543520045		Rib Plate	2		
33	565938520023		Roller	2		
34	940500100012		Bushing	16		
35	565938510003		Pin	4		
36	940500100017		Bushing	4		
37	941100300001		Screw	6		
38	560838510004		Pin	2		
39	560838510002		Push Rod	2		
40	911200100001		Oil Cup	8		
41	560898510000		Push Rod Kit	2		
42	560543520042		Axle	2		
43	910600400027		Spring Pin	4		
44	560543520041		Pin	2		
45	560543520040		Riser	2		
46	940500200005		Bushing	4		
47	505638510028		Roller	6		
47.01	910401300006		Circlip	12		
47.02	505638520119		Axle	6		
47.03	910700200017		Bearing	12		
47.04	505638520120		Roller	6		

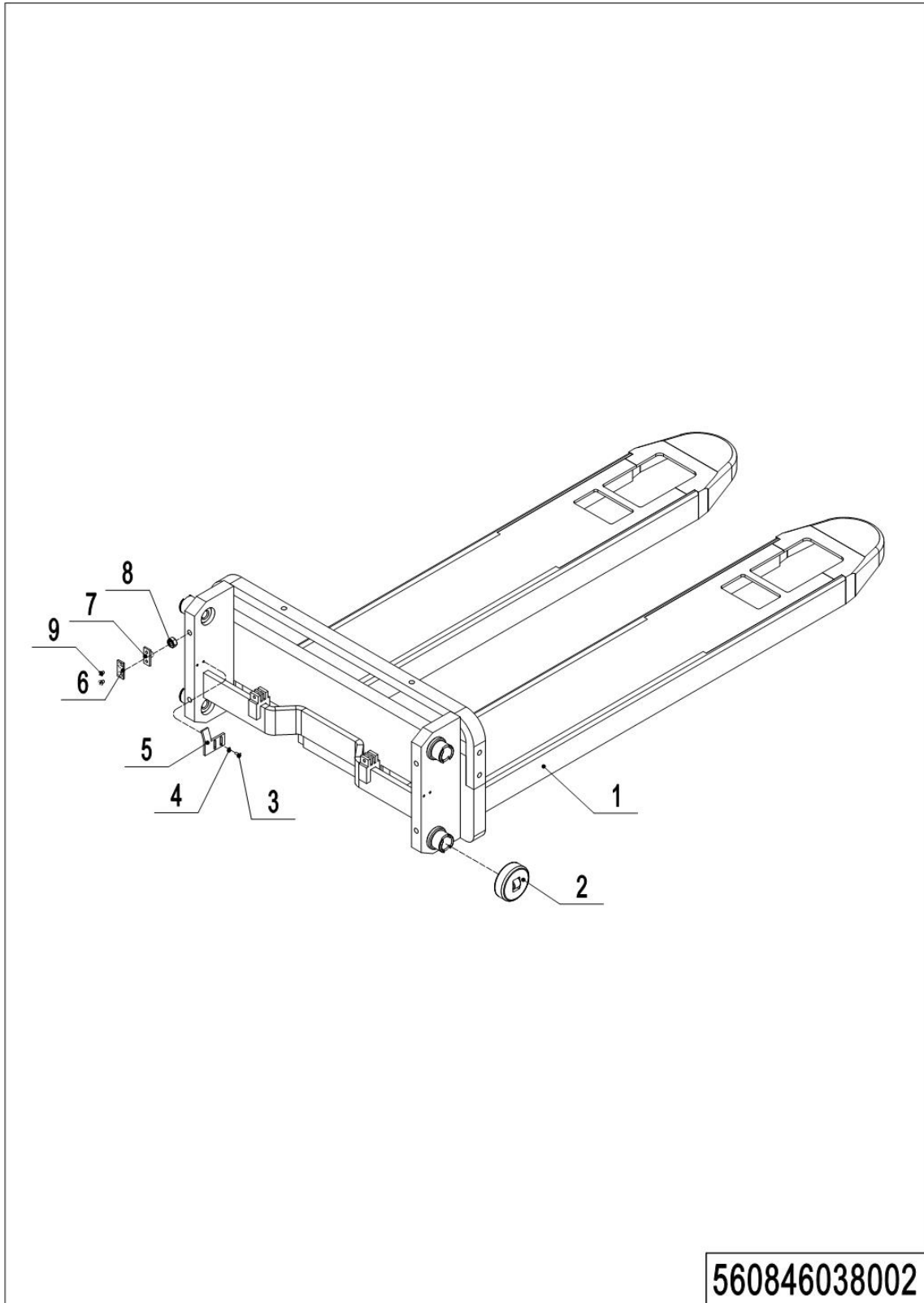
05 Fork Carriage (560846038002,PT20D One-stage Mast)

1=整包供货

2=限制供货

3=逐渐停止供货

4=不单件供货

5=见另外表单

03 Fork Carriage (560846038002,PT20D One-stage Mast)

No.	Item Code	Mark	Item Description	Qty.	Substitute	Note
1	560838010000		Fork(560x1150,210Ah)	1		
2	940200300002		Compound Roller	4		
3	910200500034		Screw	2		
4	910400500003		Spring Washer	2		
5	560838020009		Baffle	1		
6	940600100001		Magnetic Steel	1		
7	940600200002		Mounting Base	1		
8	910300300005		Nut	1		

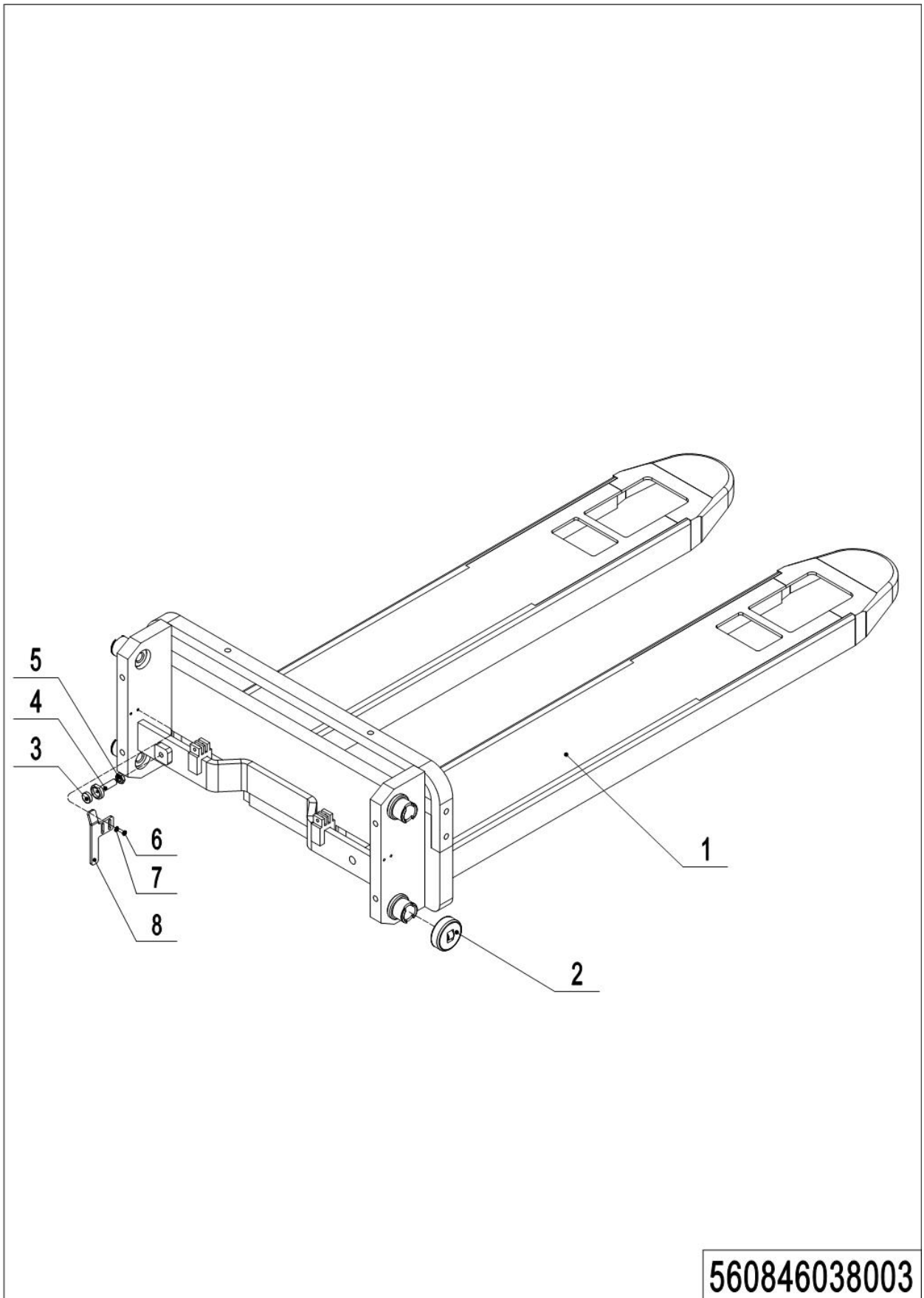
06 Fork Carriage (560846038003,PT20D One-stage Mast) (EN1175-2020)

1=整包供货

2=限制供货

3=逐渐停止供货

4=不单件供货

5=见另外表单

06Fork Carriage (560846038003,PT20D One-stage Mast) (EN1175-2020)

No.	Item Code	Mark	Item Description	Qty.	Substitute	Note
1	560838010003		Fork(560x1150,210Ah)	1		
2	940200300002		Compound Roller	4		
3	940600100001		Magnetic Steel	1		
4	940600200002		Mounting Base	1		
5	910300300005		Nut	1		
6	910200500022		Screw	2		
7	910400500003		Spring Washer	2		
8	560838020009		Baffle	1		

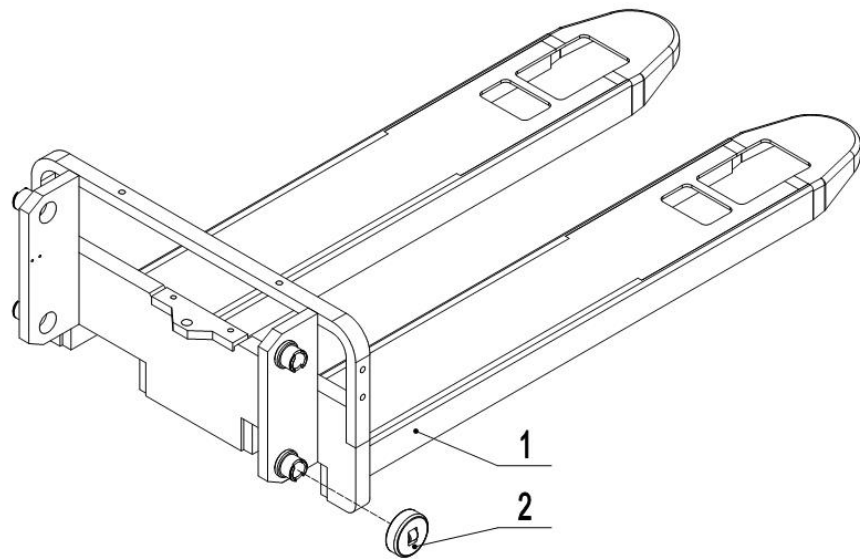
07 Fork Carriage (561146038001,PT20D Two-stage Mast)**561146038002**

07Fork Carriage (561146038001PT20D Two-stage Mast)

No.	Item Code	Mark	Item Description	Qty.	Substitute	Note
1	561138010000		Fork Carriage	1		
2	940200300002		Compound Roller	4		

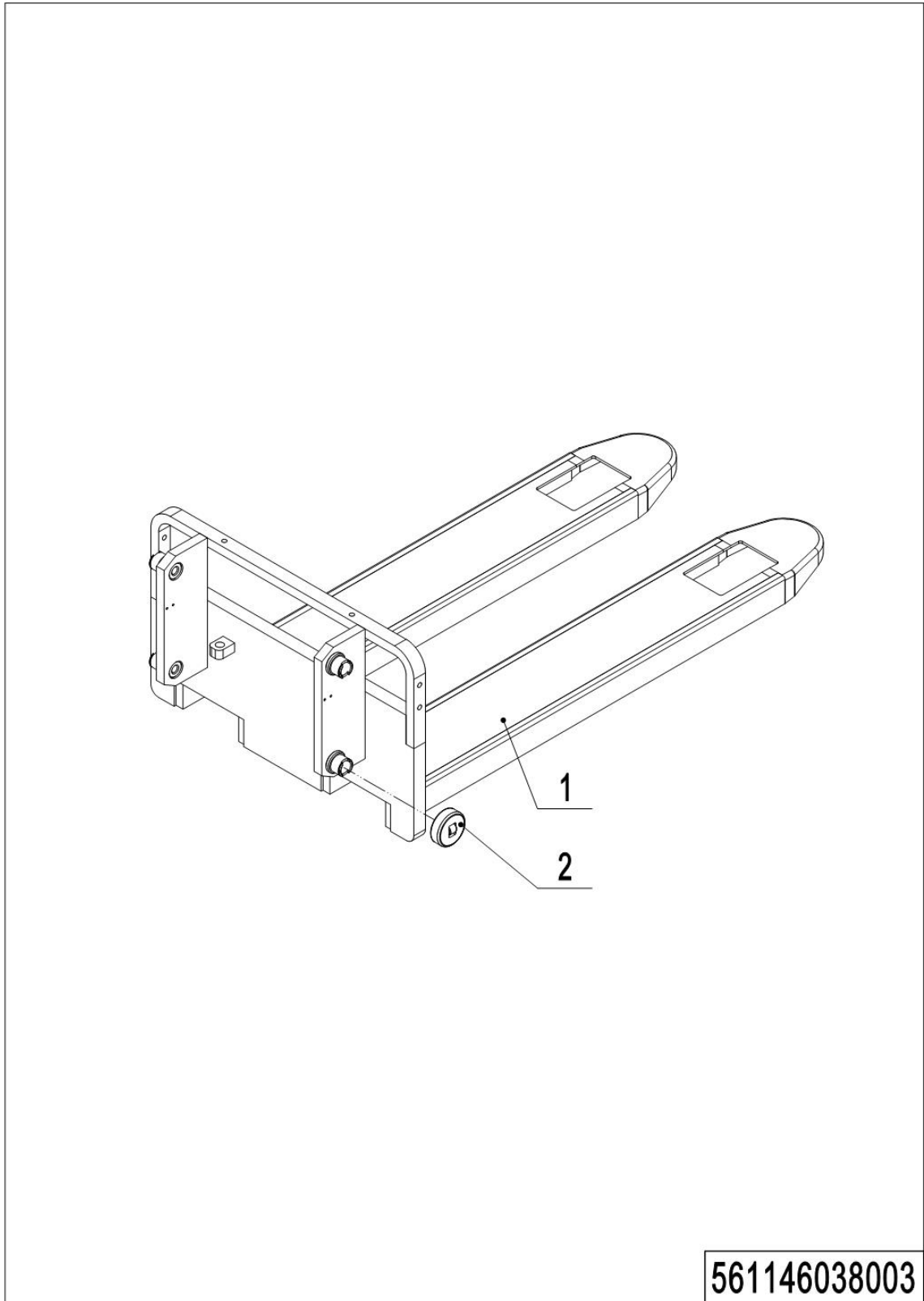
08 Fork Carriage (561146038002,PT20D Three-stage Mast)

08Fork Carriage (561146038002PT20D Three-stage Mast)

No.	Item Code	Mark	Item Description	Qty.	Substitute	Note
1	561138010001		Fork Carriage	1		
2	940200300002		Compound Roller	4		

Chapter 5: Mast System

01 One-stage Mast Standard Lift (560846043001,PT20D One-stage)

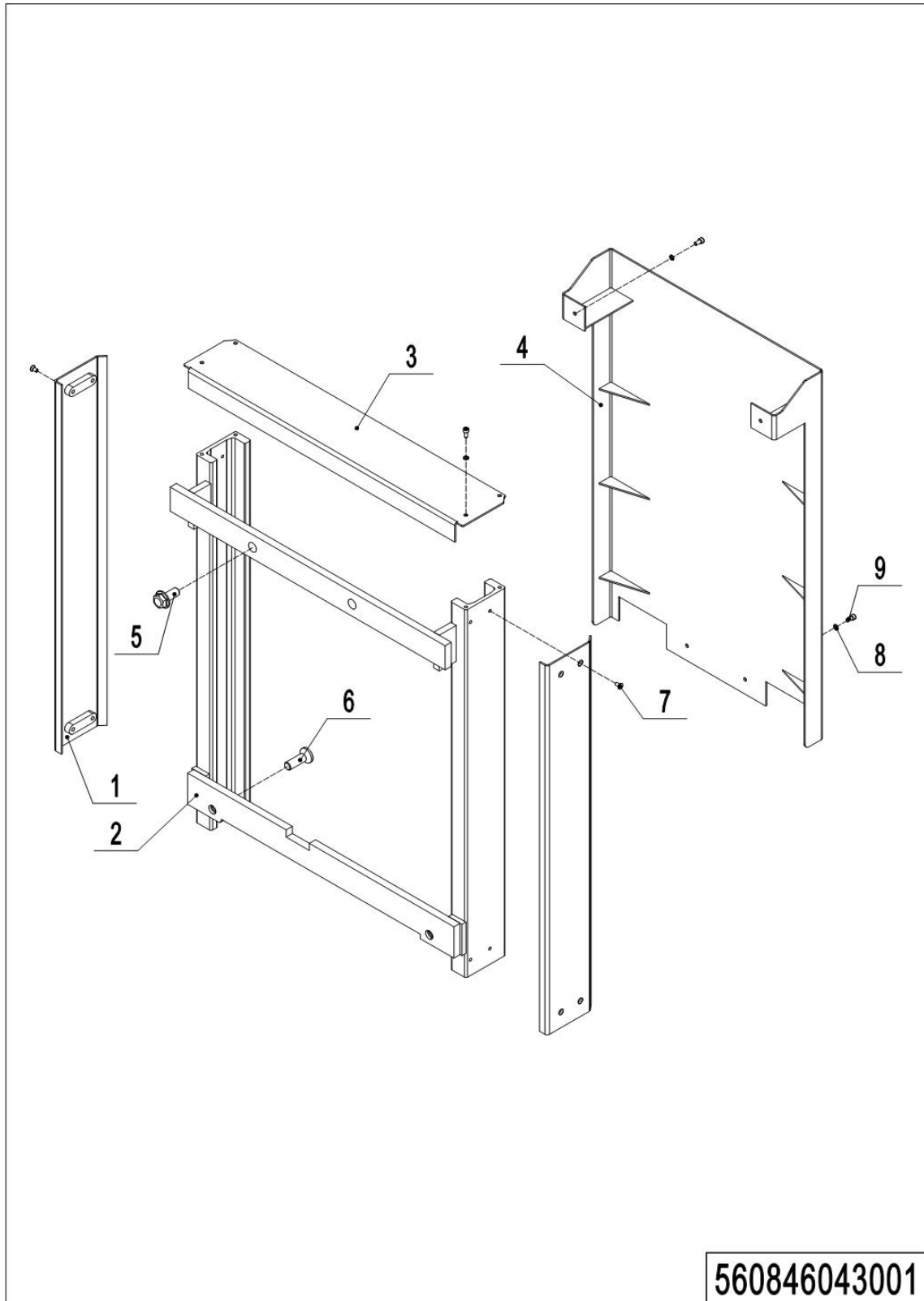

1=整包供货

2=限制供货

3=逐渐停止供货

4=不单件供货

5=见另外表单

01 One-stage Mast Standard Lift (560846043001,PT20D One-stage)

No.	Item Code	Mark	Item Description	Qty.	Substitute	Note
1	560843010000		Side Plate	2		
2	560843010001		Mast(755)	1		
3	560843020008		Close Plate	1		
4	560843010002		Close Plate	1		
5	910100800005		Bolt	2		
6	941100300002		Screw	2		
7	910200400017		Screw	8		
8	910400500005		Spring Washer	8		
9	910200200032		Screw	8		

02 Two-stage Mast Standard Lift (561146044001,PT20D)

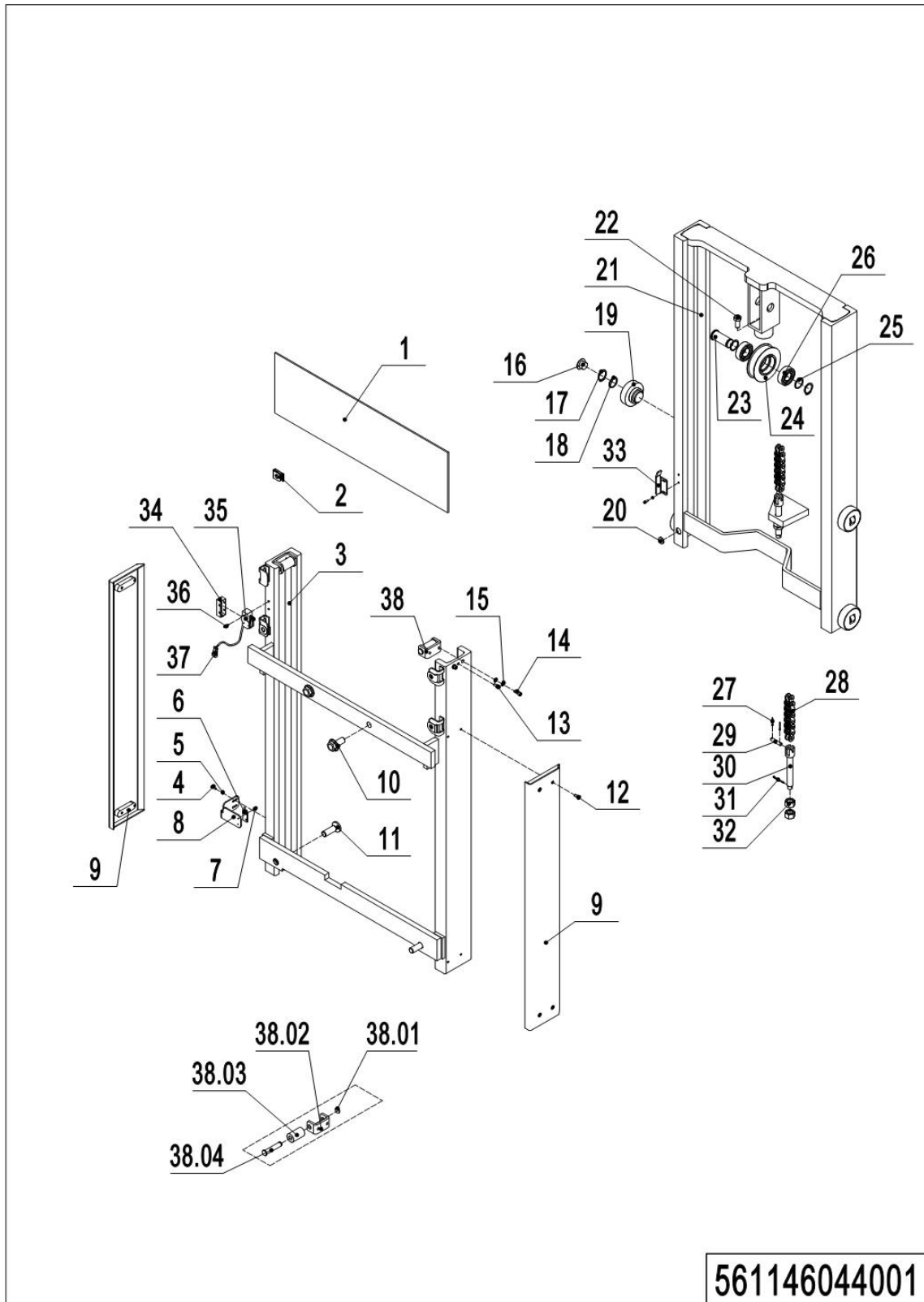

1=整包供货

2=限制供货

3=逐渐停止供货

4=不单件供货

5=见另外表单

02 Two-stage Mast Standard Lift (561146044001,PT20D)

No.	Item Code	Mark	Item Description	Qty.	Substitute	Note
1	561144020007		Guard Plate	1		
1	561144020014		Guard Plate	1		
2	940400300001		Spring Buckle	4		
3	561144010000		Outer Mast(1600)	1		
3	561144010003		Outer Mast(2000)	1		
4	910200200013		Screw	4		
5	910400500003		Spring Washer	1		
6	532633510000		Switch	1		
7	910200500010		Screw	2		
8	533545020034		Bracket	4		
9	561144010002		Side Plate	2		
10	910100800005		Bolt	2		
11	941100300002		Screw	2		
12	910200400017		Screw	8		
13	910200200053		Screw	2		
14	910200200055		Screw	4		
15	910400500006		Spring Washer	4		
16	532038020022		Subplate	4		
17	532038020021		Washer	4		
18	910401300014		Circlip	5		
19	400238020009		Roller	4		
20	940600100001		Magnetic Steel	1		
21	561144010001		Inner Mast(1600)	1		
21	561144010004		Inner Mast(2000)	1		
22	910100300049		Bolt	1		
23	532343020023		Pin	1		
24	940200400005		Sprocket	1		
25	940600500006		Washer	2		
26	910700200020		Bearing	2		
27	910600600015		Cotter Pin	2		

1=整包供货

2=限制供货

3=逐渐停止供货

4=不单件供货

5=见另外表单

02 Two-stage Mast Standard Lift (561146044001,PT20D) Continuation

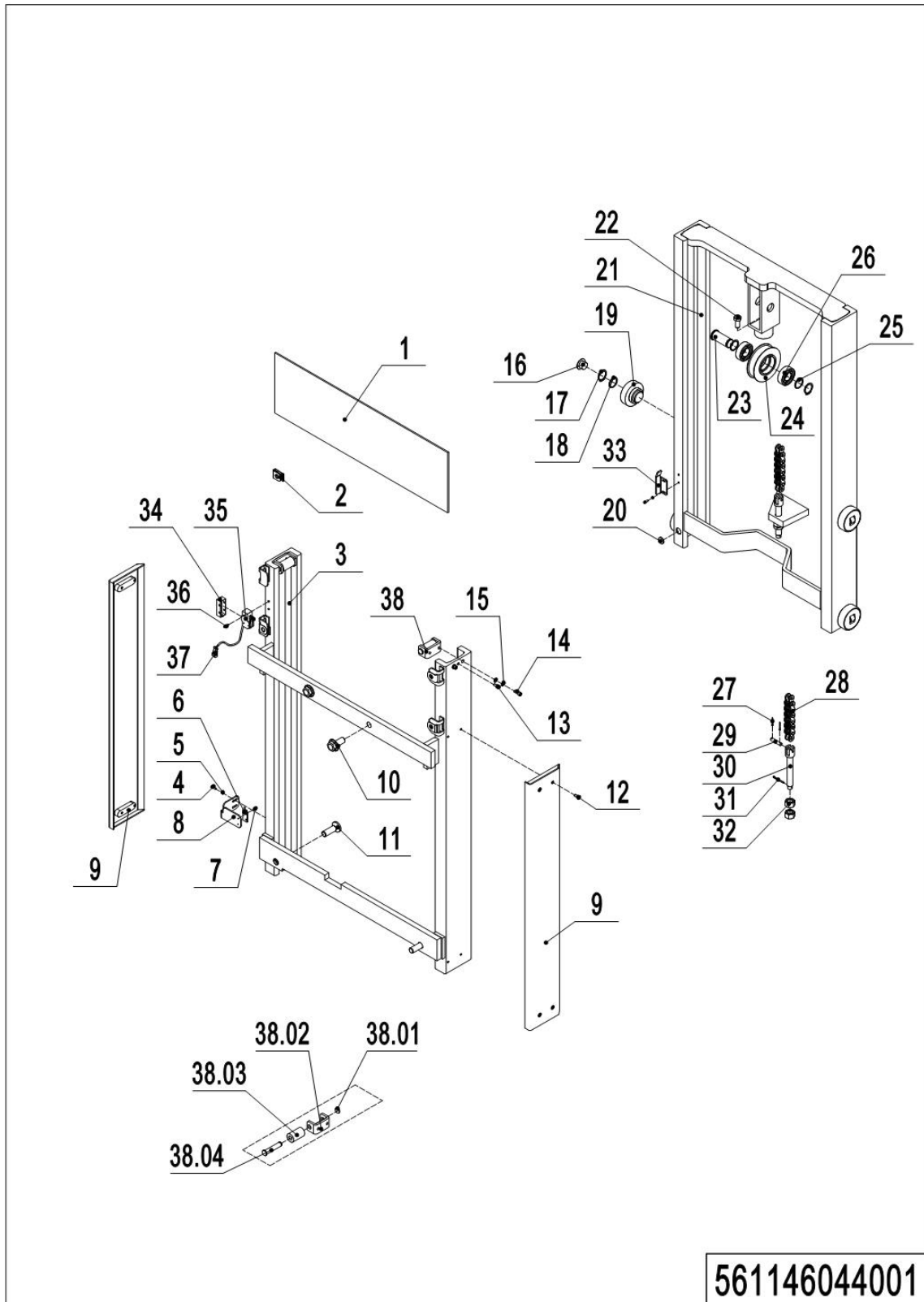

1=整包供货

2=限制供货

3=逐渐停止供货

4=不单件供货

5=见另外表单

02 Two-stage Mast Standard Lift (561146044001,PT20D) Continuation

No.	Item Code	Mark	Item Description	Qty.	Substitute	Note
28	532344510009		Chain	1		
28	561144010008		Chain	1		
29	941100800004		Pin	1		
30	941300100005		Chain Bolt	1		
31	910600600037		Cotter Pin	1		
32	910300200008		Nut	2		
33	561144020009		Mounting Plate	1		
34	920200300008		Protective Cover	1		
35	920200300003		Microswitch	1		
36	910200500028		Screw	2		
37	560833010013		Wire Harness	1		
37	560833010001		Wire Harness	1		
38	400244010002		Roller	2		
38.01	910401300003		Circlip	2		
38.02	532021520075		Wheel Mount	2		
38.03	401744020000		Roller	2		
38.04	401744020001		Pin	2		

03 Two-stage Mast Standard Lift (561146044002,PT20D) (EN1175-2020)

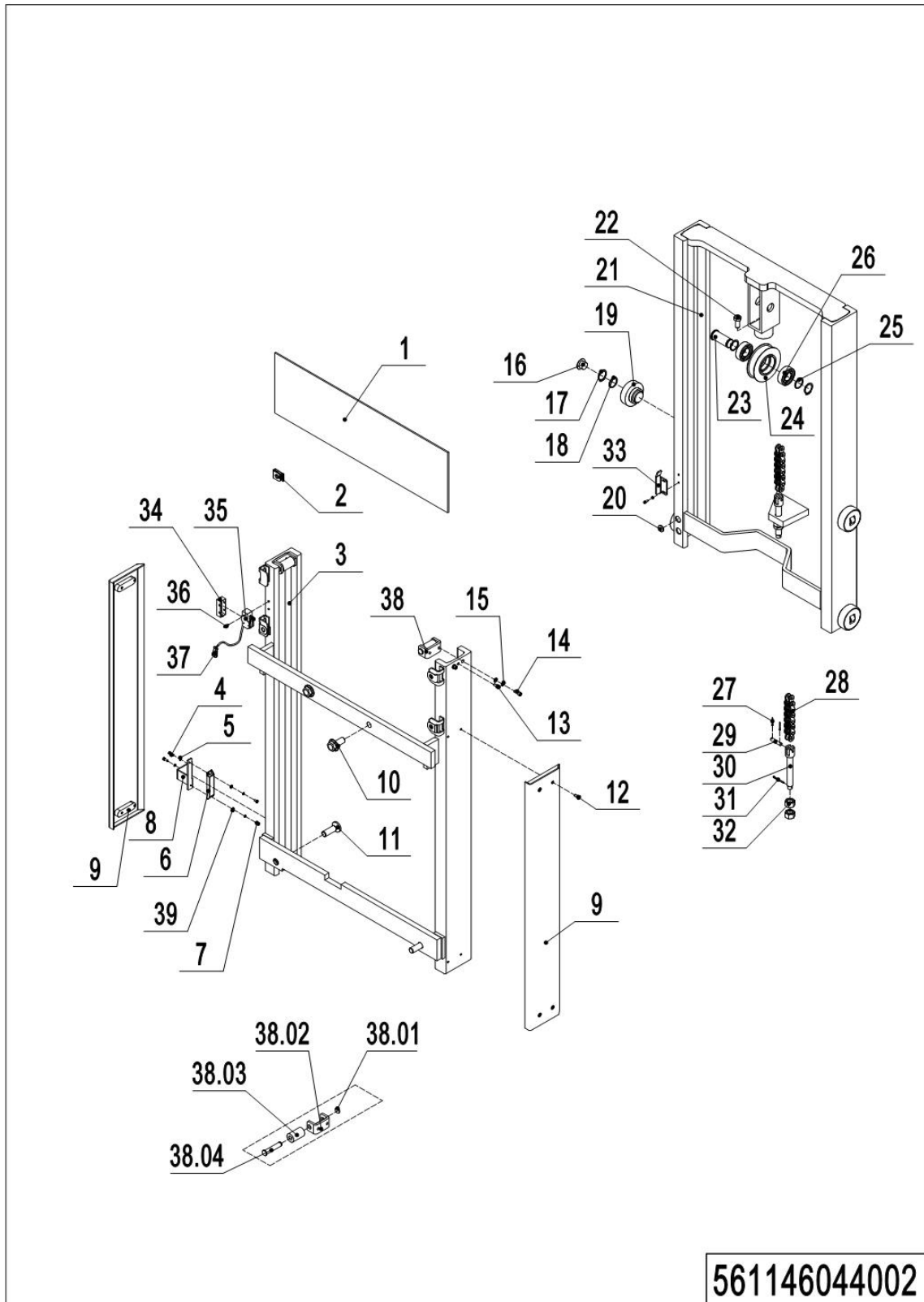

1=整包供货

2=限制供货

3=逐渐停止供货

4=不单件供货

5=见另外表单

03 Two-stage Mast Standard Lift (561146044002,PT20D) (EN1175-2020)

No.	Item Code	Mark	Item Description	Qty.	Substitute	Note
1	561144020007		Guard Plate	1		
1	561144020014		Guard Plate	1		
2	940400300001		Spring Buckle	4		
3	561144010000		Outer Mast(1600)	1		
3	561144010003		Outer Mast(2000)	1		
4	910200200013		Screw	2		
5	910400500003		Spring Washer	4		
6	560833010029		Switch	1		
7	910200300006		Screw	2		
8	561144020015		Mounting Plate	1		
9	561144010002		Side Plate	2		
10	910100800005		Bolt	2		
11	941100300002		Screw	2		
12	910200400017		Screw	8		
13	910200200053		Screw	2		
14	910200200055		Screw	4		
15	910400500006		Spring Washer	4		
16	532038020022		Subplate	4		
17	532038020021		Washer	4		
18	910401300014		Circlip	5		
19	400238020009		Roller	4		
20	940600100001		Magnetic Steel	1		
21	561144010001		Inner Mast(1600)	1		
21	561144010004		Inner Mast(2000)	1		
22	910100300049		Bolt	1		
23	532343020023		Pin	1		
24	940200400005		Sprocket	1		
25	940600500006		Washer	2		
26	910700200020		Bearing	2		
27	910600600015		Cotter Pin	2		

1=整包供货

2=限制供货

3=逐渐停止供货

4=不单件供货

5=见另外表单

03 Two-stage Mast Standard Lift (561146044002,PT20D) (EN1175-2020)

Continuation

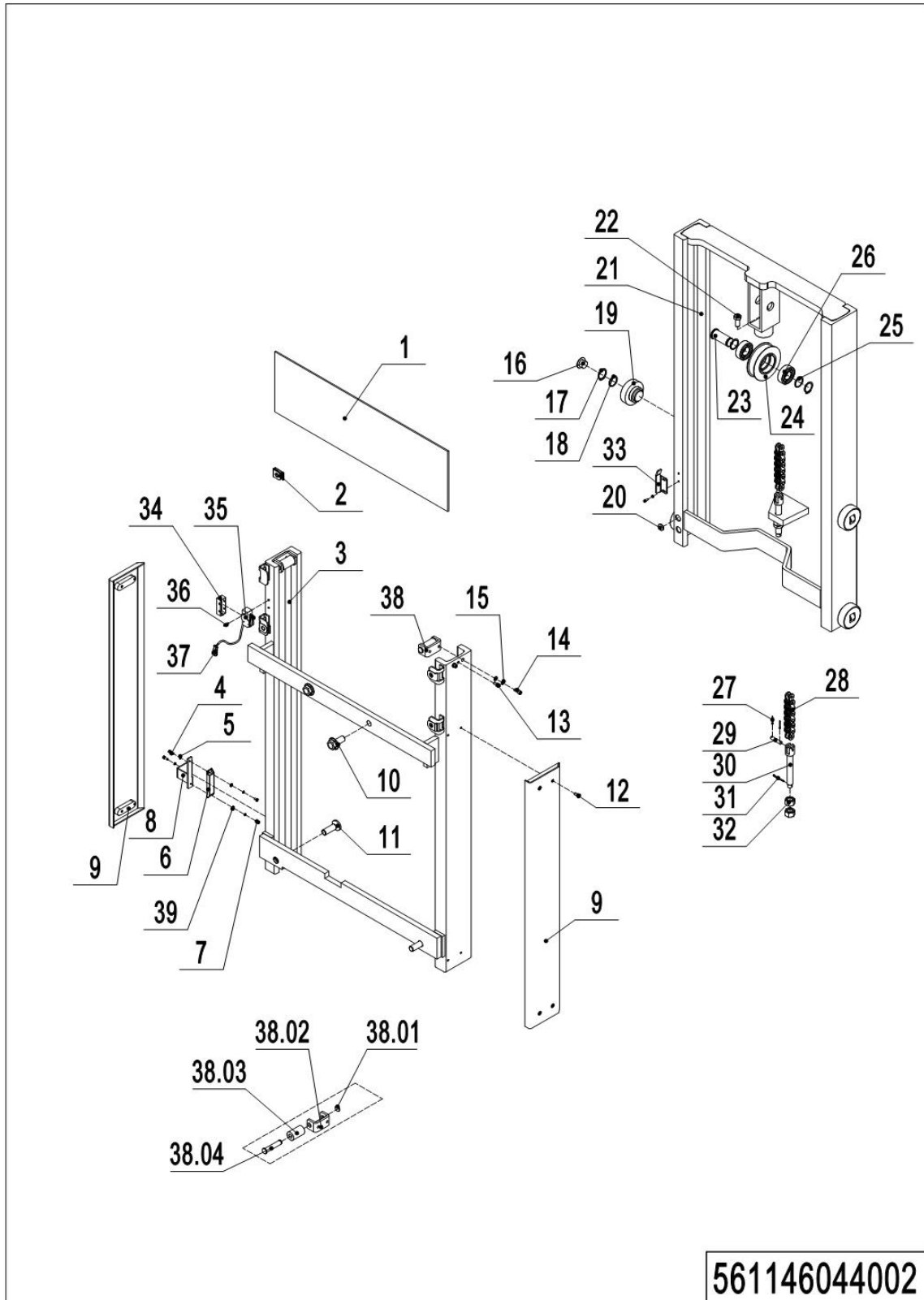

561146044002

1=整包供货

2=限制供货

3=逐渐停止供货

4=不单件供货

5=见另外表单

04 Two-stage Mast Standard Lift (561146044001,PT20D) (EN1175-2020)

Continuation

No.	Item Code	Mark	Item Description	Qty.	Substitute	Note
28	532344510009		Chain	1		
28	561144010008		Chain	1		
29	941100800004		Pin	1		
30	941300100005		Chain Bolt	1		
31	910600600037		Cotter Pin	1		
32	910300200008		Nut	2		
33	561144020009		Mounting Plate	1		
34	920200300008		Protective Cover	1		
35	920200300003		Microswitch	1		
36	910200500028		Screw	2		
37	560833010013		Wire Harness	1		
37	560833010001		Wire Harness	1		
38	400244010002		Roller	2		
38.01	910401300003		Circlip	2		
38.02	532021520075		Wheel Mount	2		
38.03	401744020000		Roller	2		
38.04	401744020001		Pin	2		
39	910400100003		Flat Washer	2		

04 Three-stage Mast Standard Lift (561146045001,PT20D)

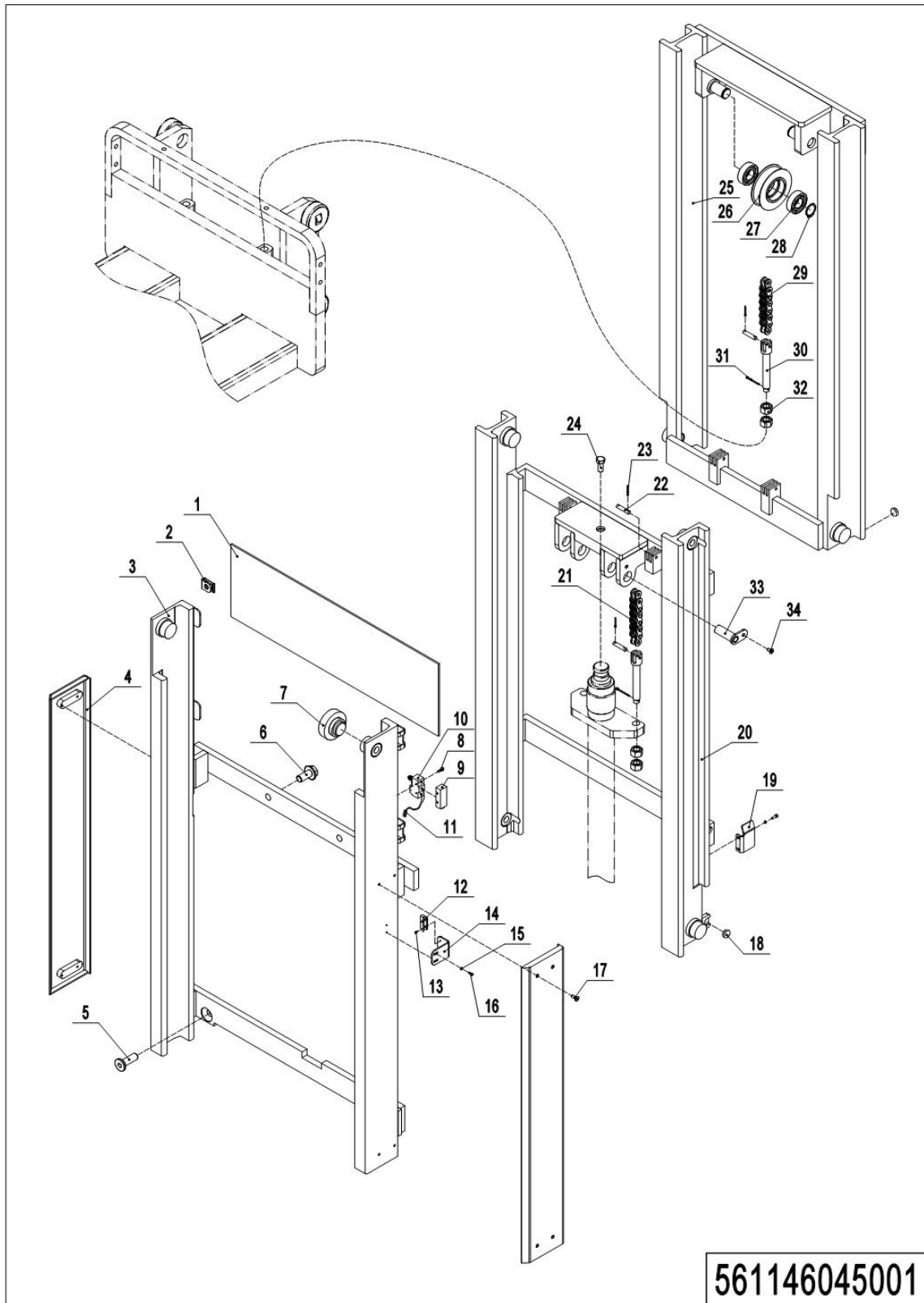

1=整包供货

2=限制供货

3=逐渐停止供货

4=不单件供货

5=见另外表单

04 Three-stage Mast Standard Lift (561146045001,PT20D)

No.	Item Code	Mark	Item Description	Qty.	Substitute	Note
1	561145020019		Guard Plate	1		
2	940400300001		Spring Buckle	4		
3	561145010000		Outer Mast	1		
4	561144010002		Side Plate	2		
5	941100300002		Screw	2		
6	910100800005		Bolt	2		
7	940200300001		Compound Roller	8		
8	910200500028		Screw	2		
9	920200300008		Protective Cover	1		
10	920200300003		Microswitch	1		
11	561133010001		Wire Harness	1		
12	532633510000		Switch	1		
13	910200500010		Screw	2		
14	561145020021		Bracket	1		
15	910400500003		Spring Washer	4		
16	910200200013		Screw	4		
17	910200400017		Screw	8		
18	940600100001		Magnetic Steel	1		
19	561145020020		Stop Plate	1		
20	561145010001		Middle Mast	1		
21	561145010005		Chain	2		
22	941100800004		Pin	8		
23	910600600015		Cotter Pin	8		
24	910100300049		Bolt	1		
25	561145010002		Inner Mast	1		
26	940200400016		Sprocket	4		
27	910700200020		Bearing	8		
28	910401300014		Circlip	4		
29	532344510009		Chain	2		
30	941300100005		Chain Bolt	4		

1=整包供货

2=限制供货

3=逐渐停止供货

4=不单件供货

5=见另外表单

04 Three-stage Mast Standard Lift (561146045001,PT20D) Continuation

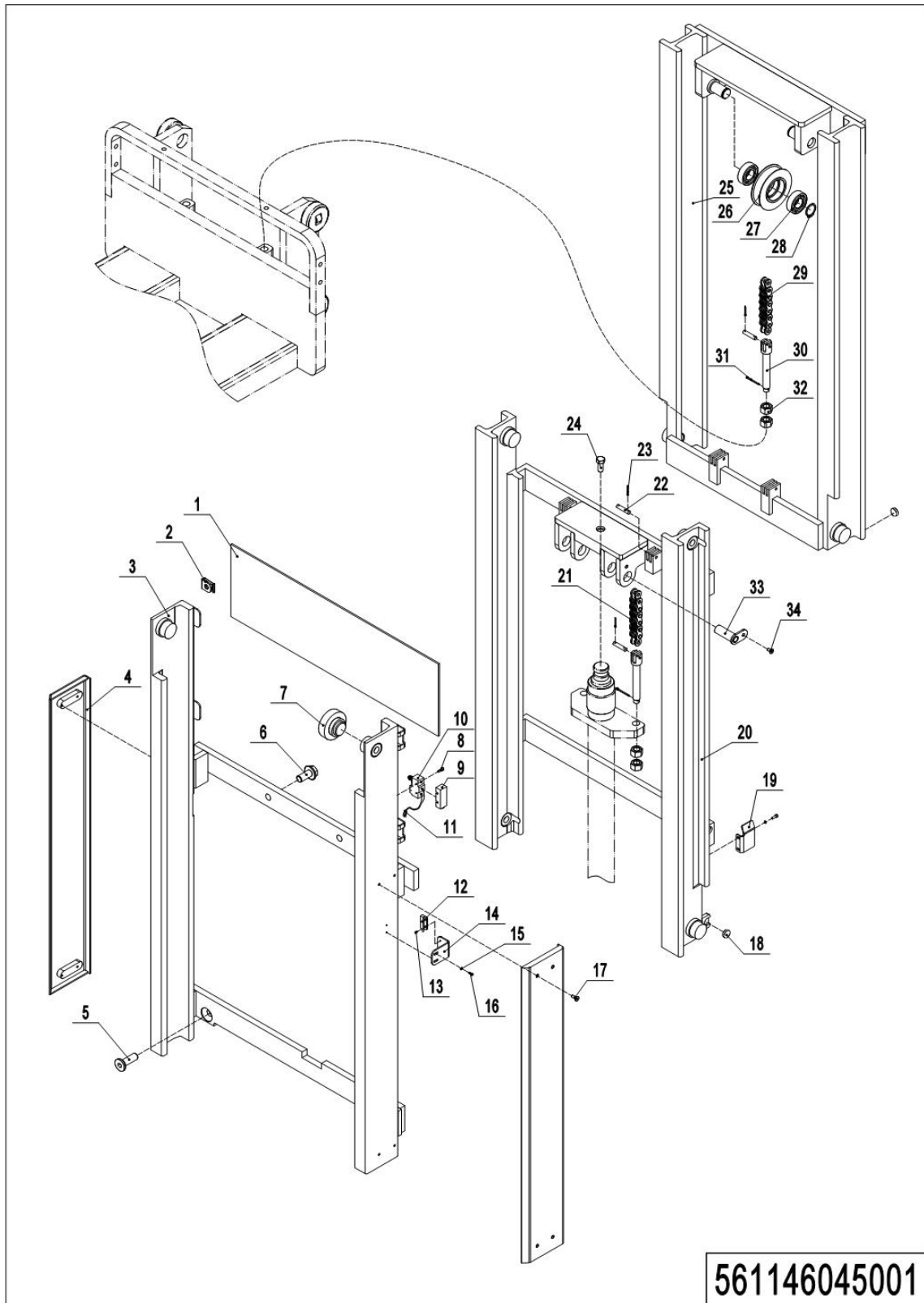

1=整包供货

2=限制供货

3=逐渐停止供货

4=不单件供货

5=见另外表单

04 Three-stage Mast Standard Lift (561146045001,PT20D) Continuation

No.	Item Code	Mark	Item Description	Qty.	Substitute	Note
31	910600600037		Cotter Pin	4		
32	910300200008		Nut	8		
33	561145010003		Pin	2		
34	910200400014		Screw	2		

05 Three-stage Mast Standard Lift (561146045002,PT20D) (EN1175-2020)

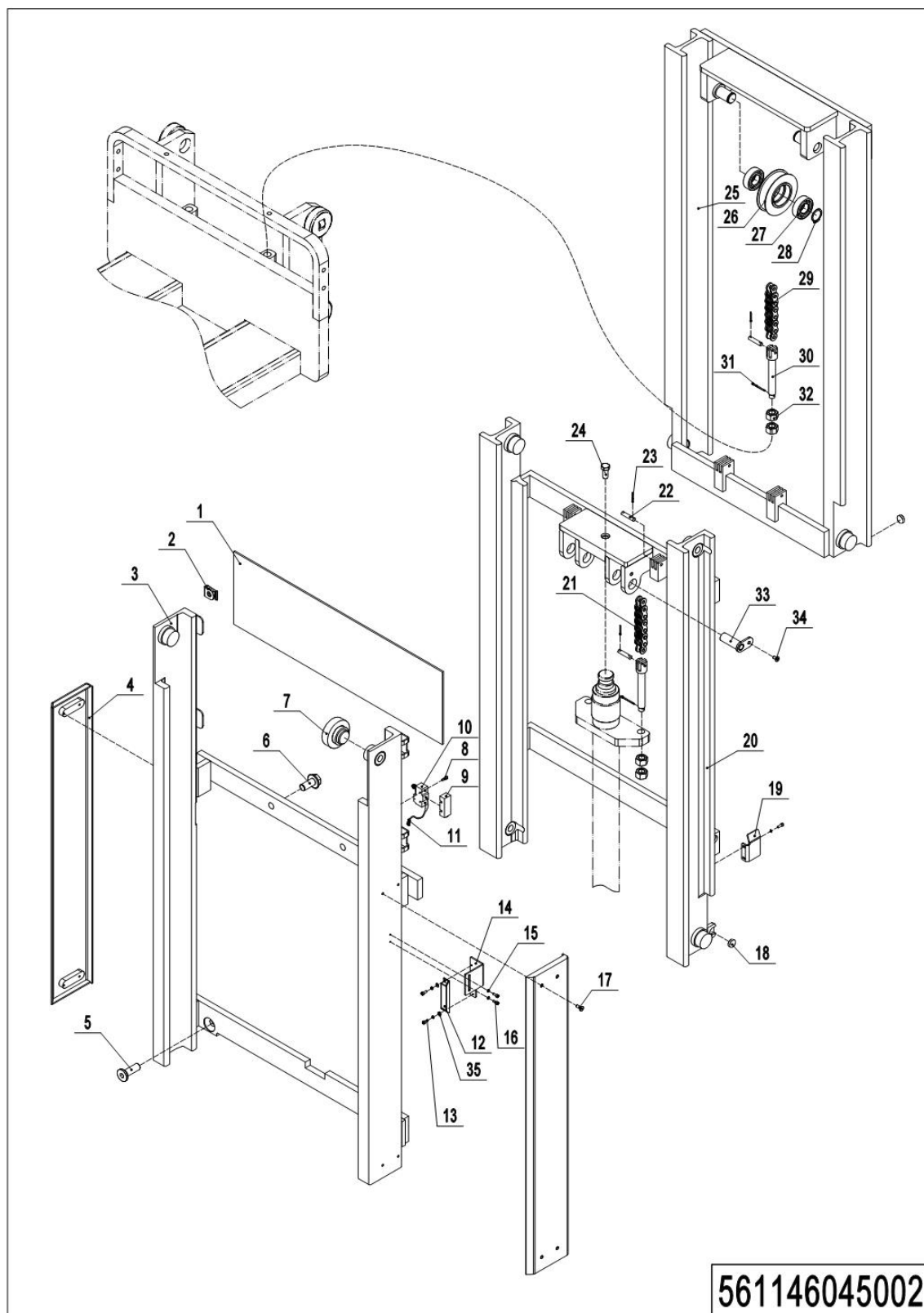

1=整包供货

2=限制供货

3=逐渐停止供货

4=不单件供货

5=见另外表单

05 Three-stage Mast Standard Lift (561146045002,PT20D) (EN1175-2020)

No.	Item Code	Mark	Item Description	Qty.	Substitute	Note
1	561145020019		Guard Plate	1		
2	940400300001		Spring Buckle	4		
3	561145010000		Outer Mast	1		
4	561144010002		Side Plate	2		
5	941100300002		Screw	2		
6	910100800005		Bolt	2		
7	940200300001		Compound Roller	8		
8	910200500028		Screw	2		
9	920200300008		Protective Cover	1		
10	920200300003		Microswitch	1		
11	561133010001		Wire Harness	1		
12	560833010029		Switch	1		
13	910200300006		Screw	2		
14	561145020023		Mounting Plate	1		
15	910400500003		Spring Washer	4		
16	910200200013		Screw	2		
17	910200400017		Screw	8		
18	940600100001		Magnetic Steel	1		
19	561145020020		Stop Plate	1		
20	561145010001		Middle Mast	1		
21	561145010005		Chain	2		
22	941100800004		Pin	8		
23	910600600015		Cotter Pin	8		
24	910100300049		Bolt	1		
25	561145010002		Inner Mast	1		
26	940200400016		Sprocket	4		
27	910700200020		Bearing	8		
28	910401300014		Circlip	4		
29	532344510009		Chain	2		
30	941300100005		Chain Bolt	4		

1=整包供货

2=限制供货

3=逐渐停止供货

4=不单件供货

5=见另外表单

05 Three-stage Mast Standard Lift (561146045002,PT20D) (EN1175-2020)

Continuation

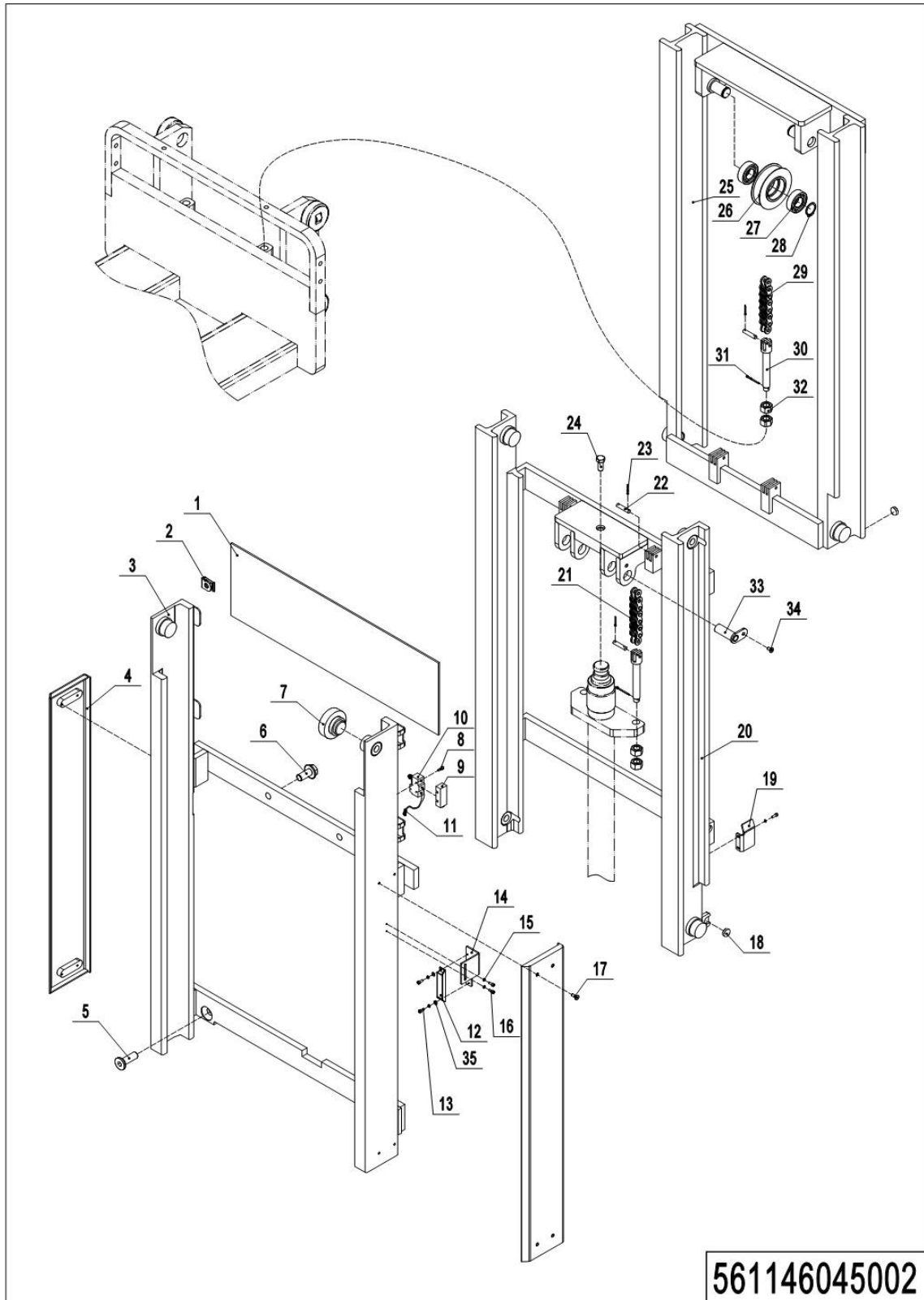

1=整包供货

2=限制供货

3=逐渐停止供货

4=不单件供货

5=见另外表单

05 Three-stage Mast Standard Lift (561146045002,PT20D) (EN1175-2020)

Continuation

No.	Item Code	Mark	Item Description	Qty.	Substitute	Note
31	910600600037		Cotter Pin	4		
32	910300200008		Nut	8		
33	561145010003		Pin	2		
34	910200400014		Screw	2		
35	910400100003		Flat Washer	2		

Chapter 6: Steering System, Braking System, Wheels

01 Tiller Unit (560846011001)

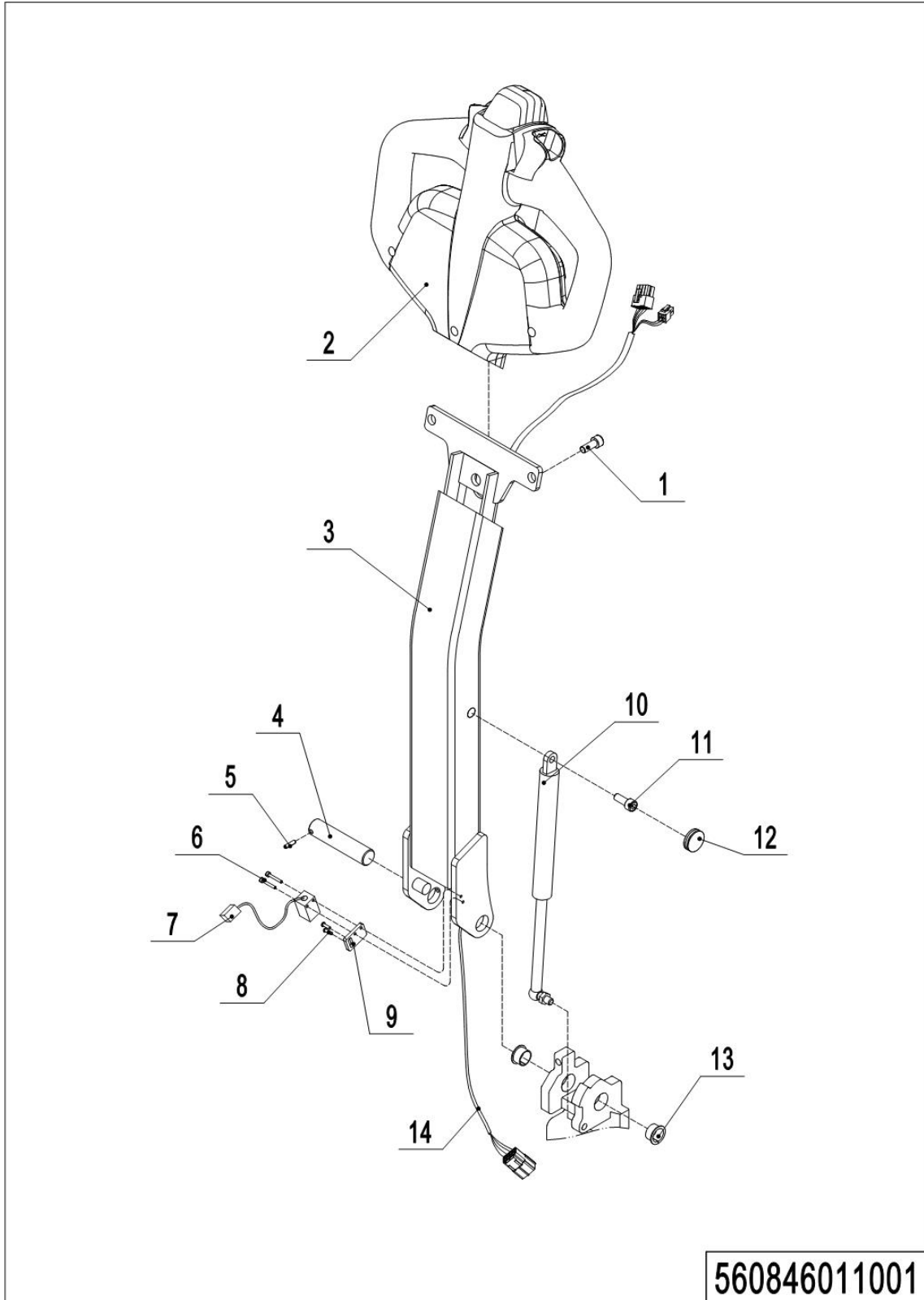

1=整包供货

2=限制供货

3=逐渐停止供货

4=不单件供货

5=见另外表单

01 Tiller Unit (505646011001)

No.	Item Code	Mark	Item Description	Qty.	Substitute	Note
1	910200200058	1	Screw	2		
2	922100100001	2	Tiller	1		见 505646011003
2	922100100099	2	Tiller	1		20CE20CE
3	504496012703	2	Tiller	1		
4	504411020011	2	Axle	1		
5	910600400009		Spring Pin	1		
6	910200200005	1	Screw	2		
7	505633510002	2	Proximity Switch	1		
8	910200200014	1	Screw	2		
9	504411020009		Baseboard	1		
10	940400100011	2	Air Spring	1		
11	941100400001	1	Screw	1		
12	502311020009		Close Plate	1		
13	940500200005		Bushing	2		
14	534733010032	2	Wire Harness	1		
15	560833010026	2	Wire Harness	1		20CE

02 Control Handle (505646011003)

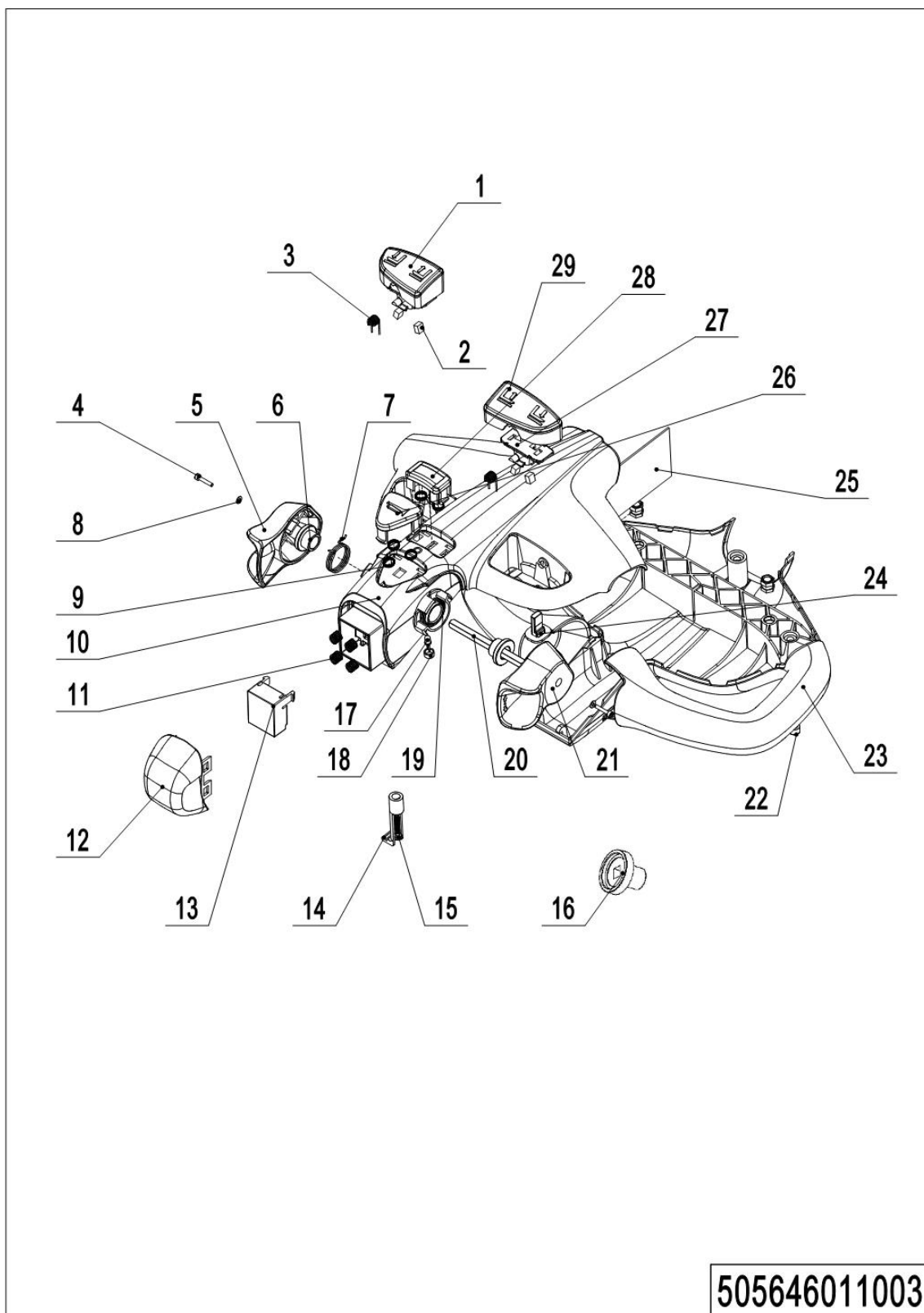

1=整包供货

2=限制供货

3=逐渐停止供货

4=不单件供货

5=见另外表单

02 Control Handle (505646011003)

No.	Item Code	Mark	Item Description	Qty.	Substitute	Note
1	505698520016		Button cap	1		
2	505698520005		Magnet	4		
3	505698520018		Torsional Spring	2		
4	505698520008		Screw	2		
5	505698520001		Traction lever	1		
6	505698520004		Sleeve	2		
7	505698520027		Torsional Spring	1		
8	505698520009		Washer	2		
9	505698520003		Spring	5		
10	505698520014		Handle Cap	1		
10	505698520099		Handle Cap	1		20CE
11	505698520006		Spring	4		
12	505698520020		Button Cap-	1		
13	505698520019		Pedestal	1		
13	505698520100		Pedestal	1		20CE
14	505698520012		Clamp	1		
15	505698520023		Screw	1		
16	505698520102		Plate	2		
17	505698520024		Light	1		
18	505698520025		Lamp Holder	1		
19	505698520026		Torsional Spring	1		
20	505698520011		Axle-Traction lever	1		
21	505698520010		Traction lever	1		
22	505698520007		Screw	3		
23	505698520015		Handle Cap	1		
24	505698520013		Sensor	2		
25	505698520028		circuit Board	1		
25	505698520101		circuit Board	1		20CE

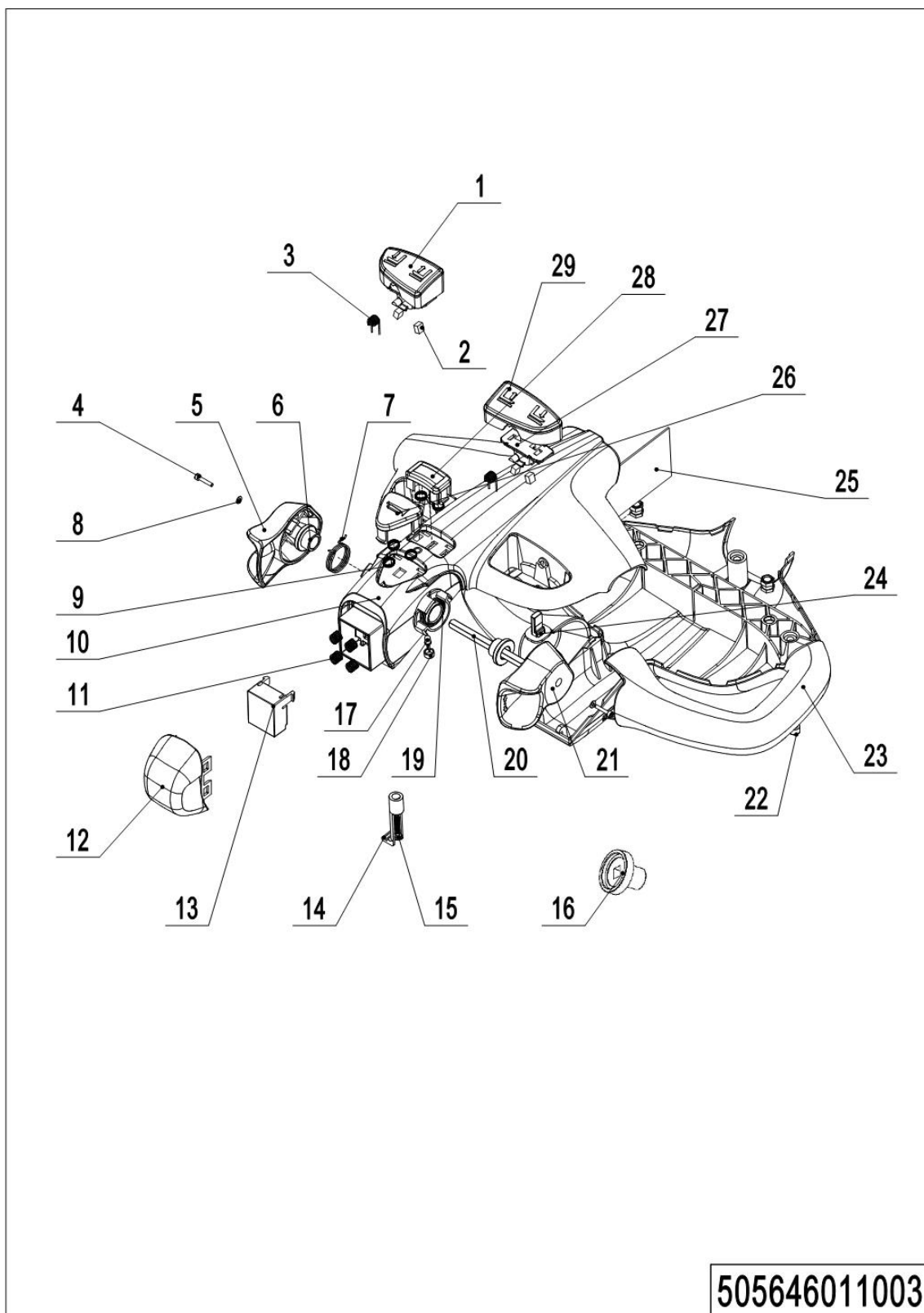
02 Control Handle (505646011003) Continuation

02 Control Handle (505646011003) Continuation

No.	Item Code	Mark	Item Description	Qty.	Substitute	Note
26	505698520002		Button	1		
27	505698520017		Fixing Base	2		
28	505698520021		Button Cap	1		

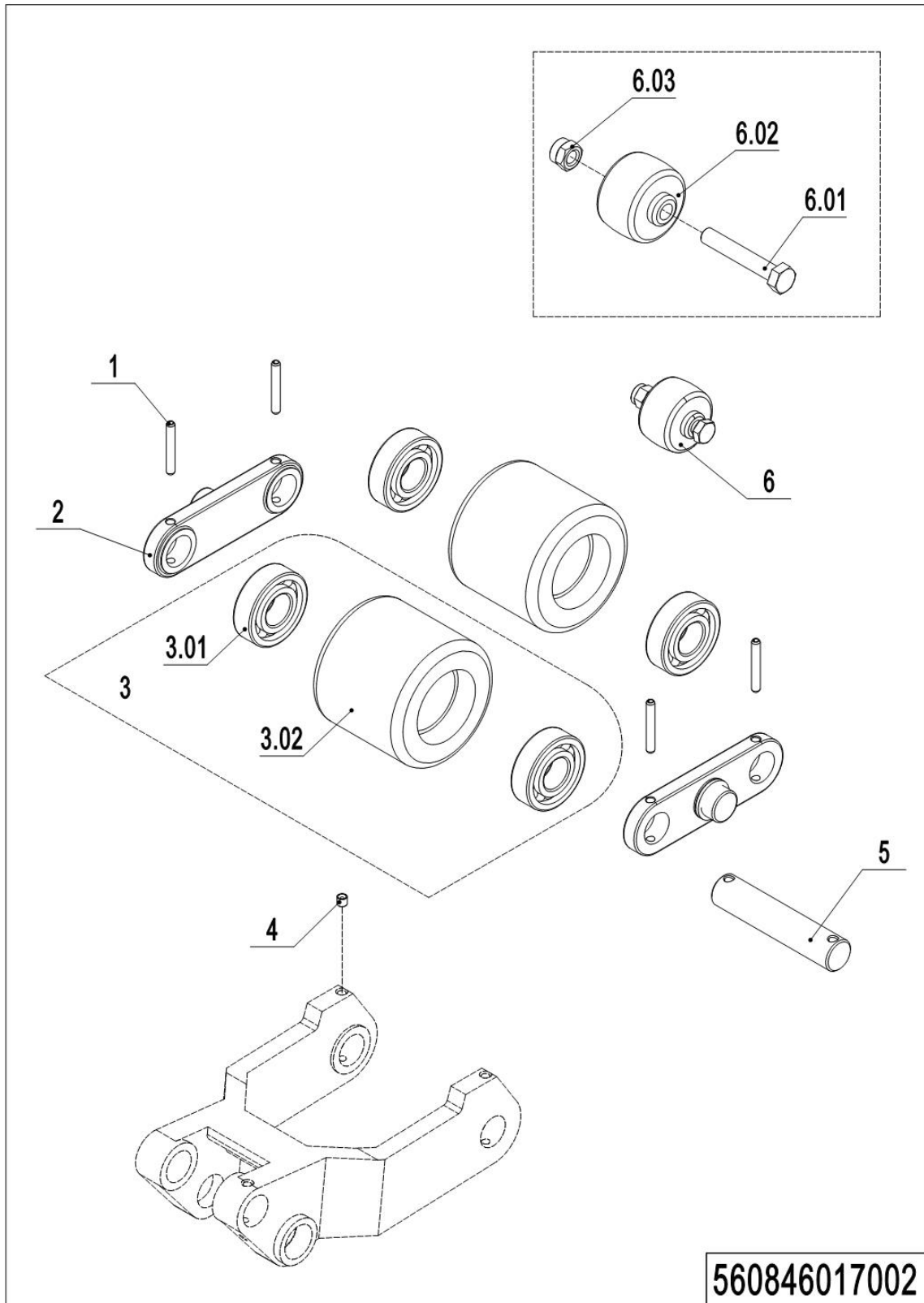
03 Load Wheel (Tandem) (560846017002)

1=整包供货

2=限制供货

3=逐渐停止供货

4=不单件供货

5=见另外表单

03 Load Wheel (Tandem) (560846017002)

No.	Item Code	Mark	Item Description	Qty.	Substitute	Note
1	910600400028		Spring Pin	4		
2	565917020000		Plate	2		
3	502398510002		Wheel	2		
3.01	910700200019		Bearing	4		
3.02	940300300005		WheelΦ80x70	2		
4	911200100001		Oil Cup	2		
5	560517020000		Axle	2		
6	502398510003		Pulley components	2		
6.01	910300500005	1	Nut	2		
6.02	505638520039		Running Pulley	2		
6.03	910100100035	1	Bolt	2		

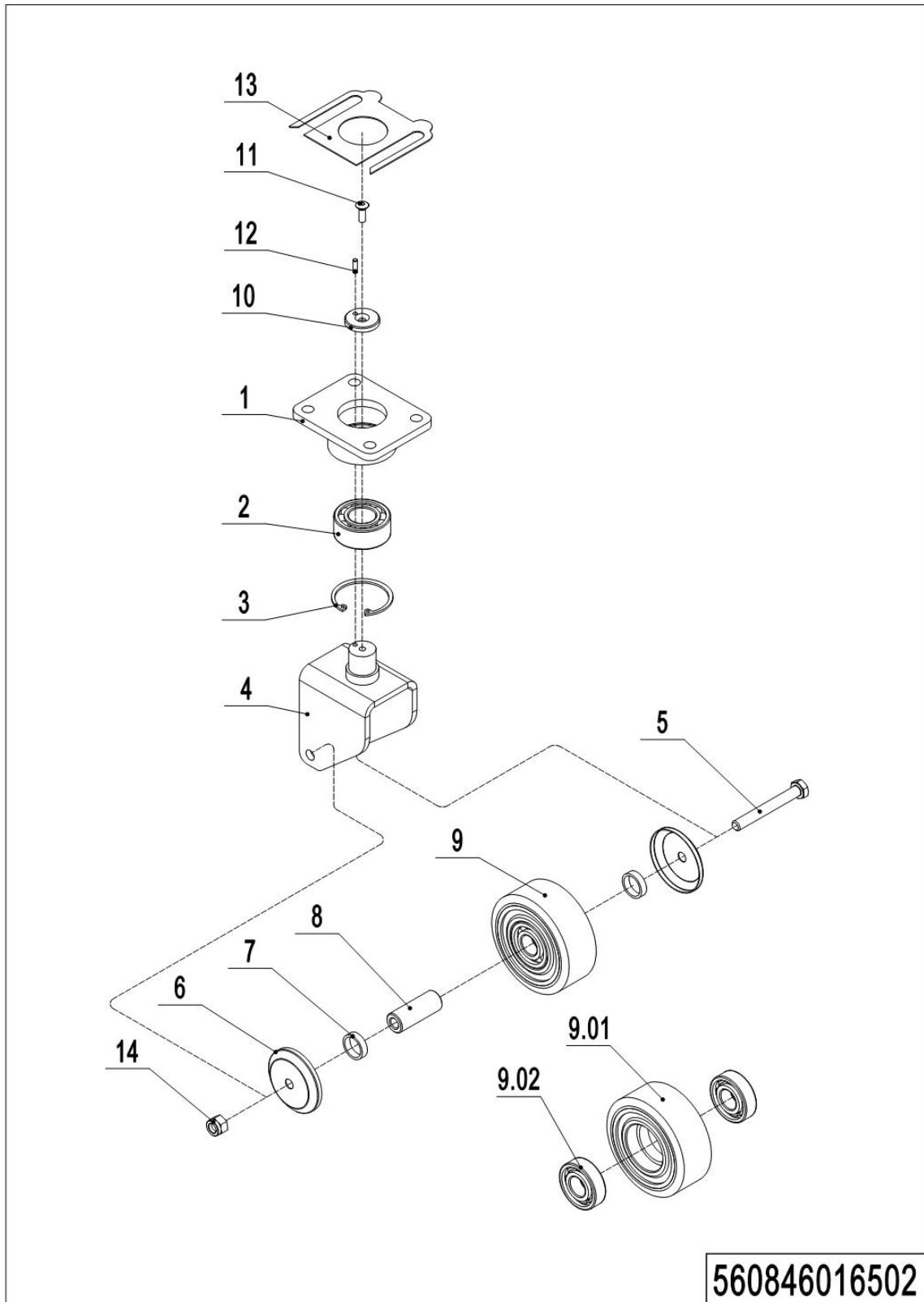
04 Caster (560846016502)

1=整包供货

2=限制供货

3=逐渐停止供货

4=不单件供货

5=见另外表单

04 Caster (560846016502)

No.	Item Code	Mark	Item Description	Qty.	Substitute	Note
1	504416510002		Plate	2		
2	910700500002		Bearing	2		
3	910401400016		Circlip	2		
4	560816510001		Wheel Carrier	2		
5	910100100038		Bolt	2		
6	505616520011		Dust Cap	4		
7	505616520012		Check Ring	4		
8	505616520013		Bushing	2		
9	505698510000		Wheel	2		
9.01	940300300018		WheelΦ100x40	2		
9.02	910700200019		Bearing	4		
10	505616520007		Retaining Ring	2		
11	941100300001		Screw	2		
12	910600100004		Cylindrical Pin	2		
13	505616520014		Pad	4		
14	910300500005		Nut	1		

05 Control Handle, detong (505646011002)

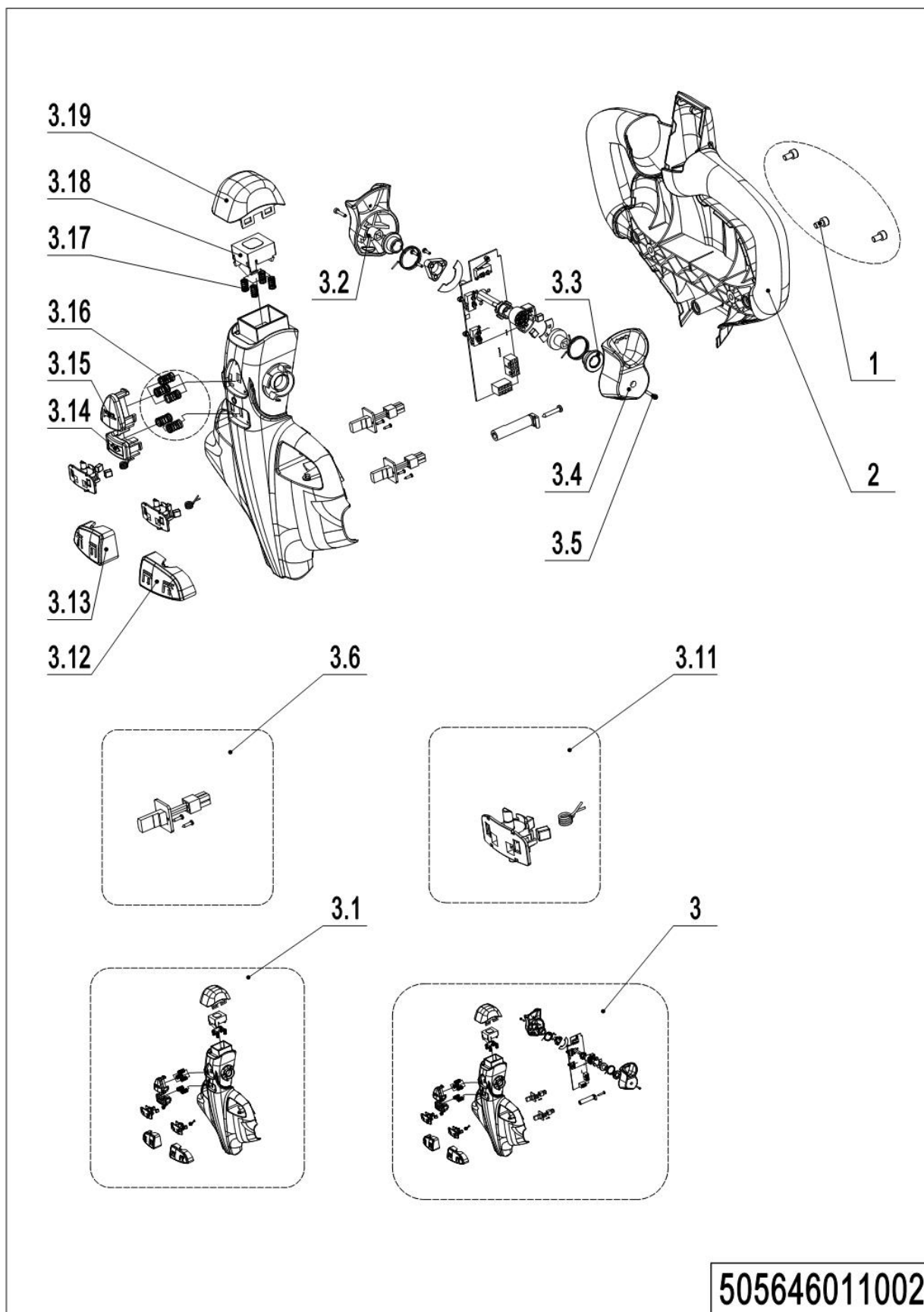

05 Control Handle, detong (505646011002)

序号	物料编码	Mark	物料名称	数量	替代零件号	说明
1	910200200032	1	Screw	3		M6×10
2	505698520124	2	Handle Cap	1		
3	505698510024	2	Handle Cap Kit	1		
3.1	505698510021	2	Handle Cap Kit	1		
3.11	505698510023	2	Sensor	1		
3.12	505698520113	2	Button	1		
3.13	505698520114	2	Button	1		
3.14	505698520115	2	Button	1		
3.15	505698520116	2	Button	1		
3.16	505698520117	2	Spring	5		
3.17	505698520118	2	Spring	4		
3.18	505698520119	2	Cover	1		
3.19	505698520120	2	Cover	1		
3.2	505698520121	2	Traction lever	1		
3.3	505698520122	2	Sleeve	2		
3.4	505698520123	2	Traction lever	1		
3.5	910200200004	1	Screw	2		M3×16
3.6	505698510022	2	Magnetic Steel Base Kit	1		

Chapter 7: Electrical Parts

01 Charger (560846036501)

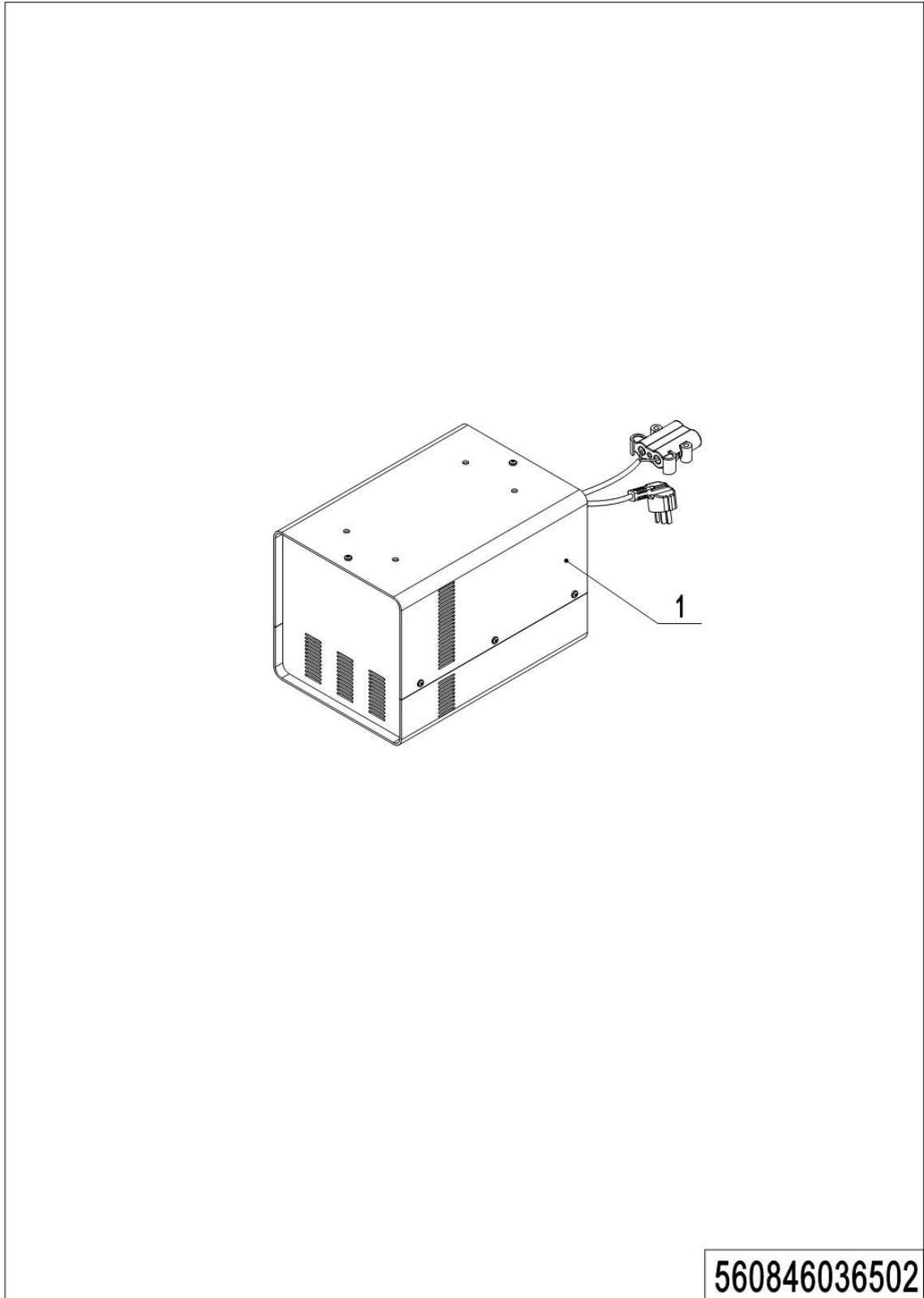

01 Charger (560846036501)

No.	Item Code	Mark	Item Description	Qty.	Substitute	Note
1	921000200001	2	Charger24V30A(Aisa-CHN)	1		
1	921000200002	2	Charger24V30A(Aisa-ENG)	1		
1	921000200003	2	Charger24V30A(EU)	1		
1	921000200004	2	Charger24V30A(AUS)	1		
1	921000200005	2	Charger24V30A(ENG)	1		
1	921000200006	2	Charger24V30A(USA)	1		

02 Charger (560846036502)

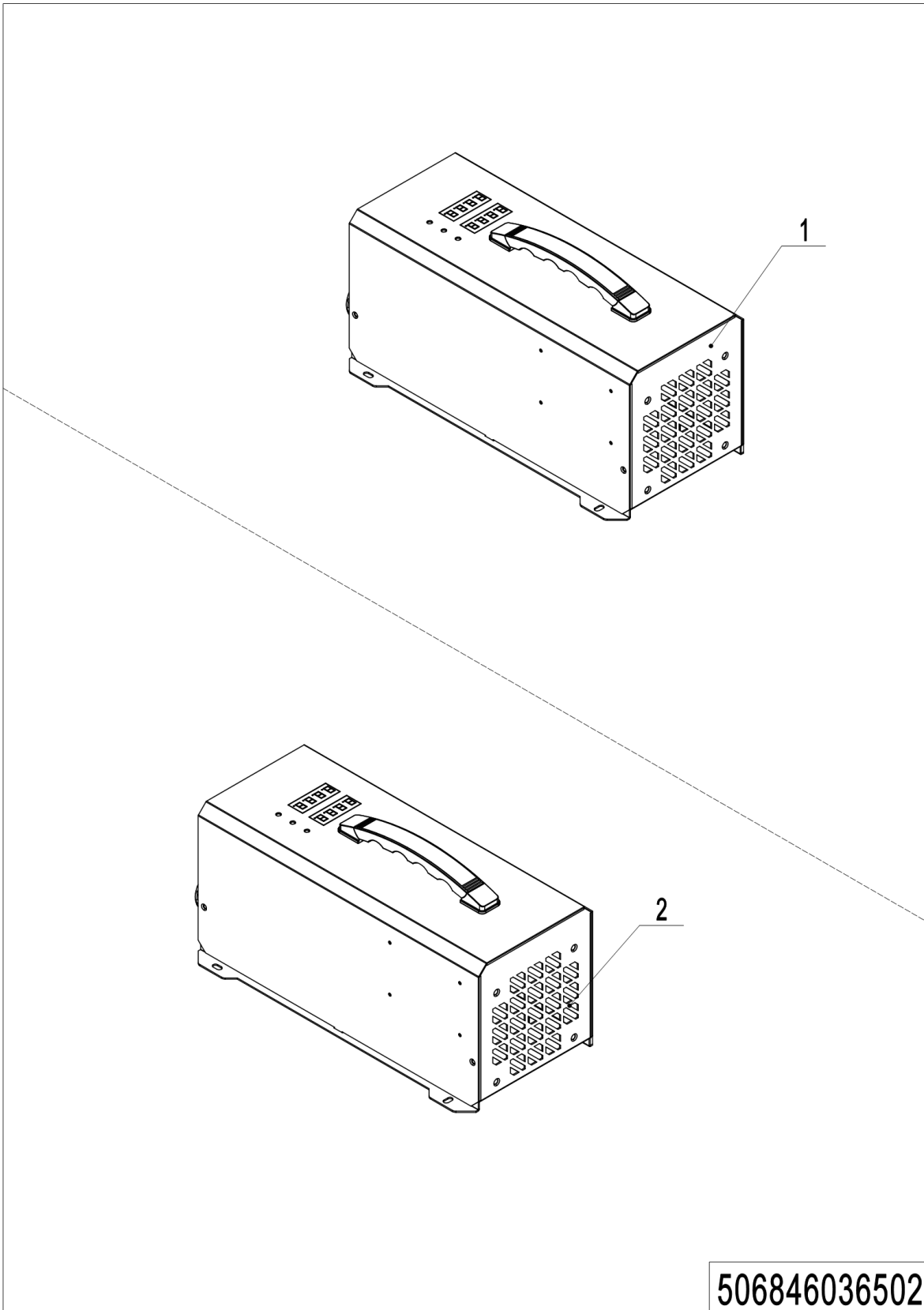

02 Charger (560846036502)

序号	物料编码	Mark	物料名称	数量	替代零件号	说明
1	921000200522		Charger 24V60A (Aisa-CHN)	1		ADP
1	921000200649		Charger 24V60A (Aisa)	1		SW
1	921000200523		Charger 24V60A (Aisa-ENG)	1		ADP
1	921000200524		Charger 24V60A (EU)	1		ADP
1	921000200525		Charger 24V60A (ENG)	1		ADP
1	921000200526		Charger 24V60A (AUS)	1		ADP
1	921000200527		Charger 24V60A (ISR)	1		ADP
1	921000200528		Charger 24V60A (ARG)	1		ADP
1	921000200529		Charger 24V60A (RSA)	1		ADP
1	921000200530		Charger 24V60A (USA)	1		ADP
1	921000200530		Charger 24V60A (THA)	1		ADP
2	921000200531		Charger 24V80A (Aisa-CHN)	1		ADP
2	921000200652		Charger 24V80A (Aisa-ENG)	1		SW
2	921000200662		Charger 24V80A (Aisa-CHN)	1		SW
2	921000200532		Charger 24V80A (Aisa-ENG)	1		ADP
2	921000200533		Charger 24V80A (EU)	1		ADP
2	921000200534		Charger 24V80A (ENG)	1		ADP
2	921000200535		Charger 24V80A (AUS)	1		ADP
2	921000200536		Charger 24V80A (ISR)	1		ADP
2	921000200537		Charger 24V80A (ARG)	1		ADP
2	921000200538		Charger 24V80A (RSA)	1		ADP
2	921000200539		Charger 24V80A (USA)	1		ADP
2	921000200630		Charger 24V80A (THA)	1		ADP

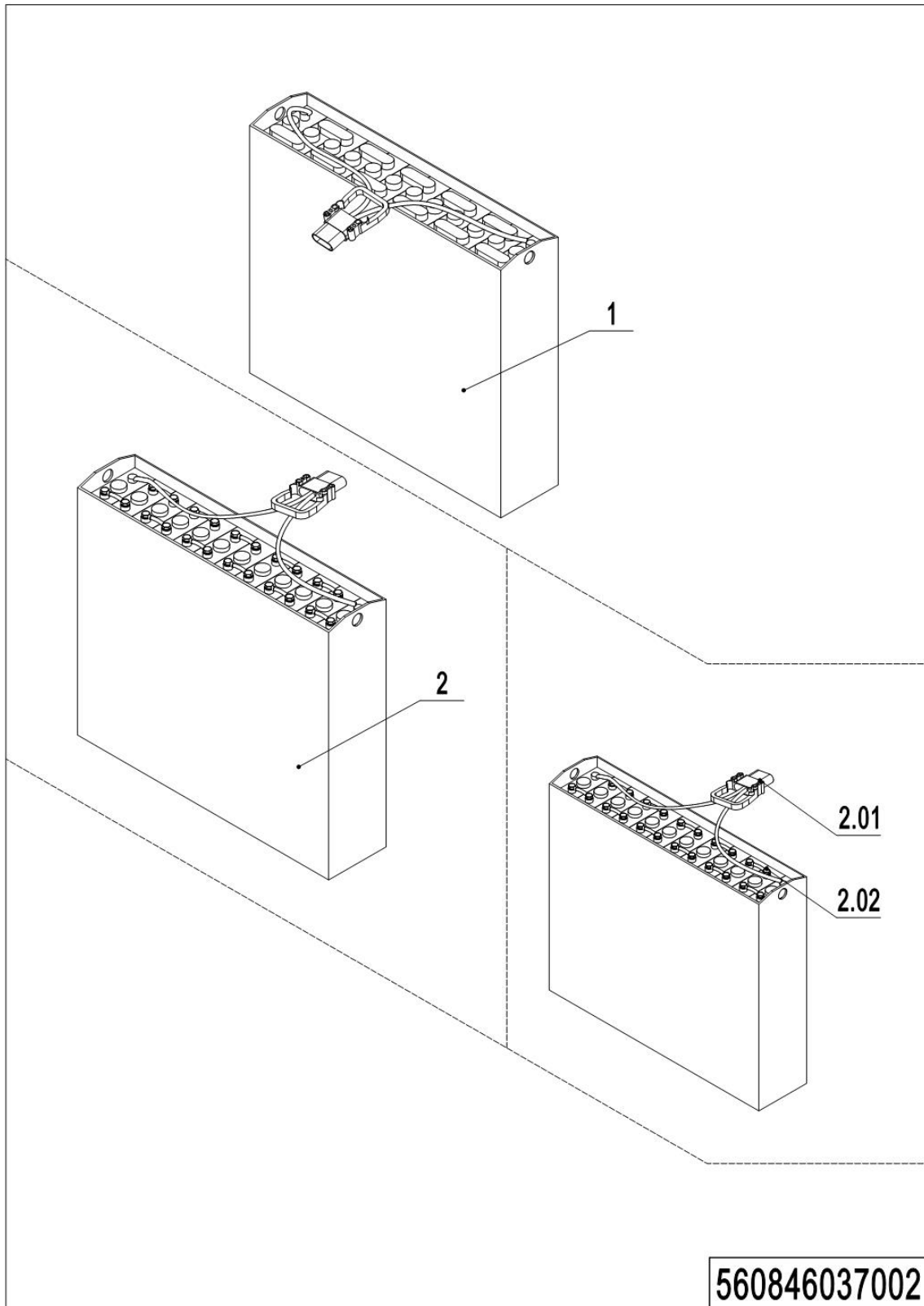
03 Traction Battery (560846037002)

03 Traction Battery (560846037002)

No.	Item Code	Mark	Item Description	Qty.	Substitute	Note
1	560837010001		Battery24V210Ah(welded)	1		
2	560837010000		Battery24V210Ah	1		
2.01	560898510002		Connector	1		
2.02	505698520000		Bolt	24		

04 lithium battery (560846037002)

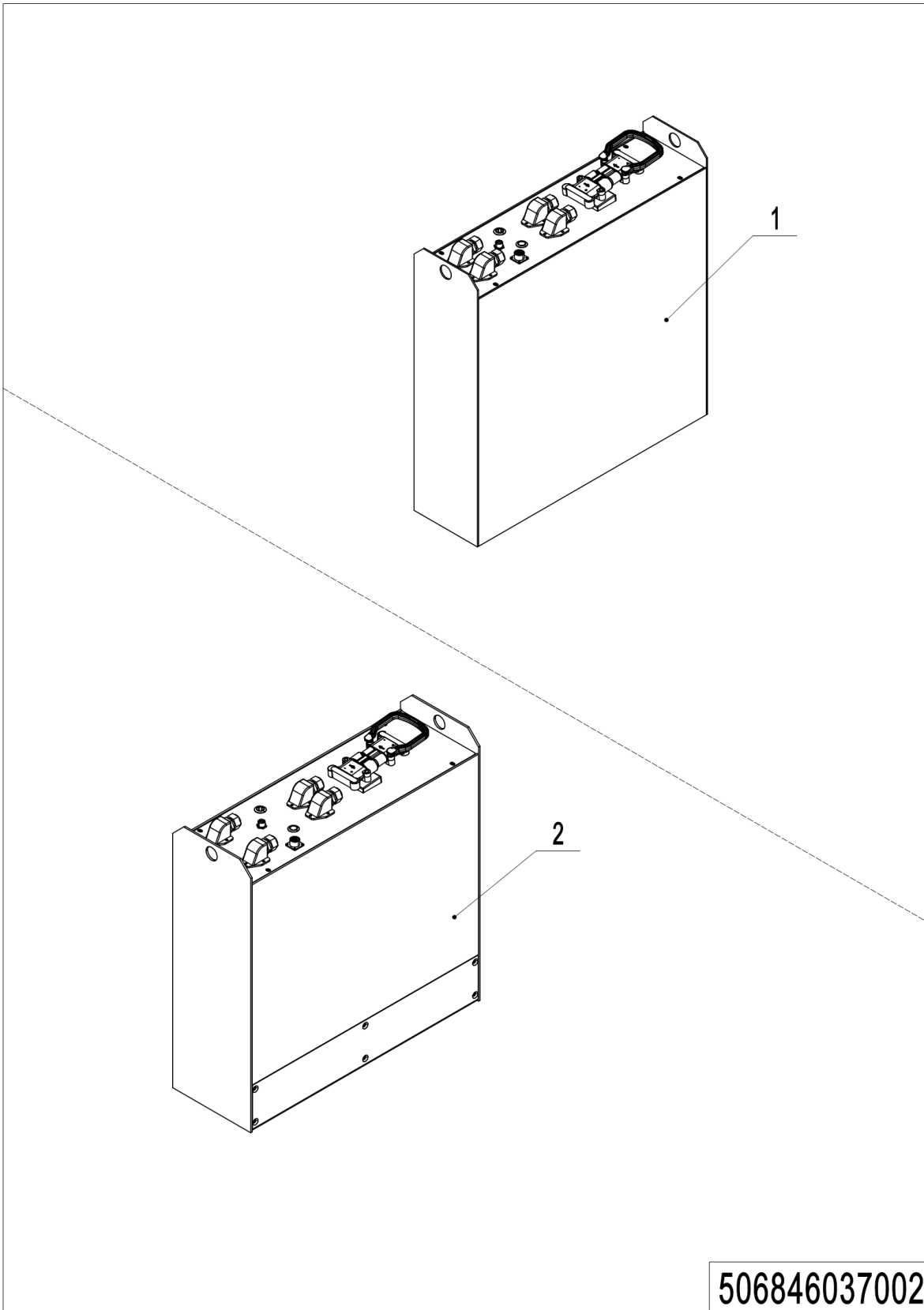

04 lithium battery (560846037002)

No.	Item Code	Mark	Item Description	Qty.	Substitute	Note
1	920600100308		Li Battery 24V100Ah1HR	1		
2	920600100310		Li Battery 24V150Ah1HR	1		

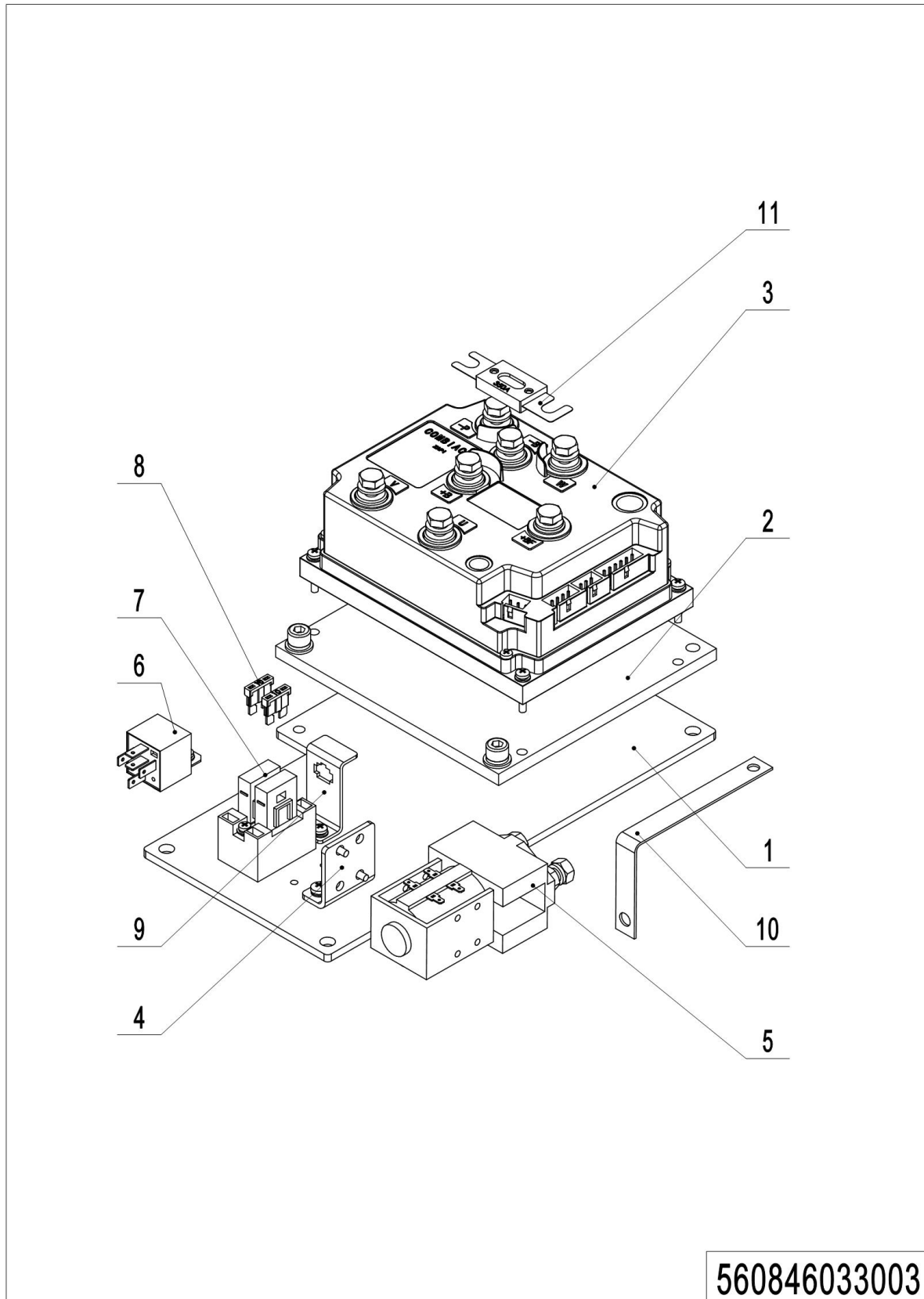
05 Controller, COMBIACX (560846033003)

05 Controller, COMBIACX (560846033003)

No.	Item Code	Mark	Item Description	Qty.	Substitute	Note
1	560821520014		Mounting Plate	1		
2	534733020000		Plate	1		
3	921400100048		Controller	1		
4	921300400006		Holder	1		
5	920700100002		Contactactor	1		
6	920800100001		Relay	1		
7	920100400005		Fuse Holder	1		
8	920100200002		Fuse	2		
9	921300300001		Holder	1		
10	560833020000		Copper Busbar	1		
11	920100100013		Fuse	1		

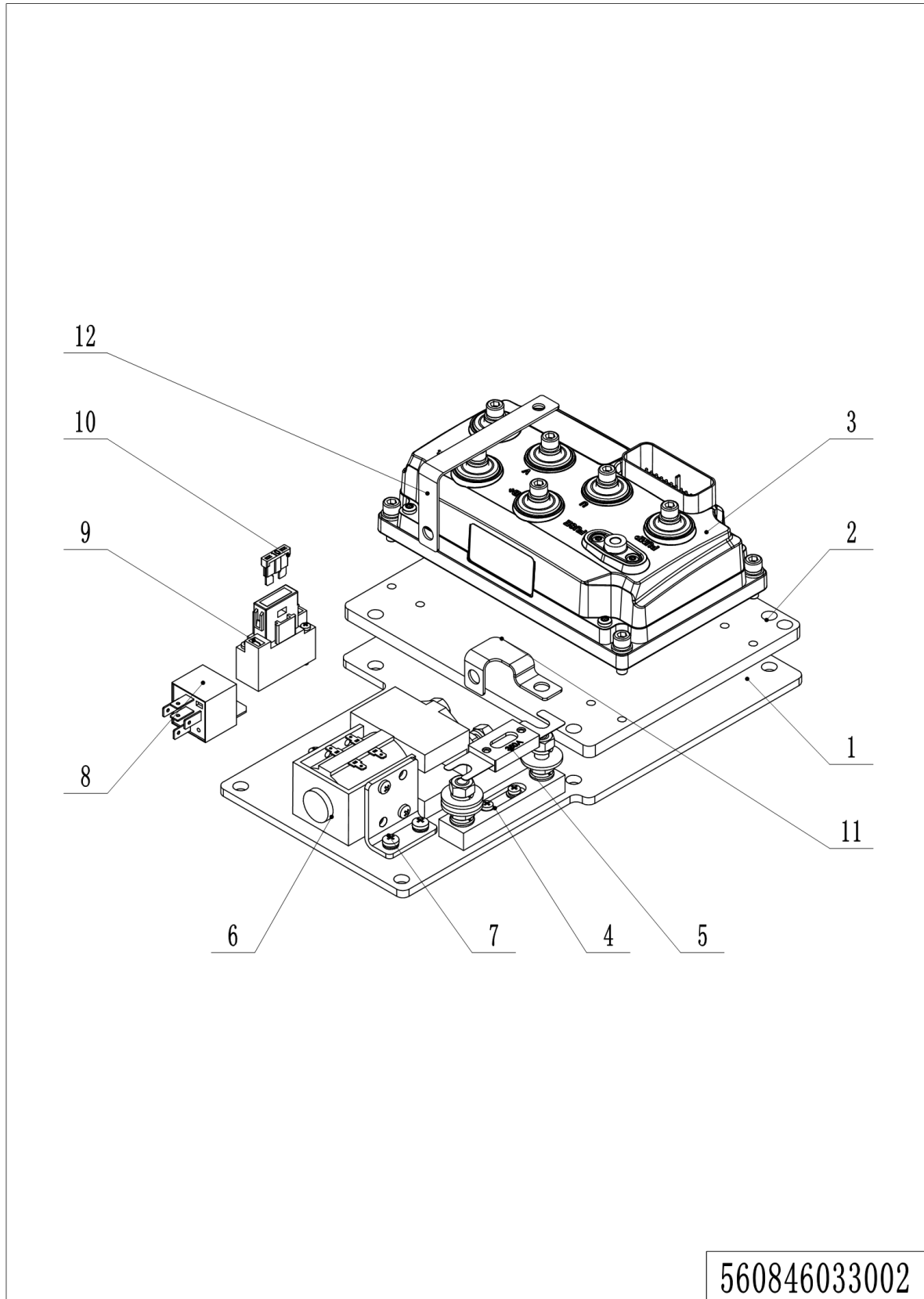
06 Controller, Curtis-F (560846033002) (EN1175-2020)

06 Controller, Curtis-F (560846033002, 20CE)

序号	物料编码	Mark	物料名称	数量	替代零件号	说明
1	560821520030		Mounting Plate	1		
2	534733020003		Plate	1		
3	921400100124		Controller	1		
4	920100400002		Fuse Holder	1		
5	920100100013		Fuse	1		
6	920700100002		Holder	1		
7	921300400004		Holder	1		
8	920800100011		Relay	1		
9	920100400006		Fuse Holder	1		
10	920100200002		Fuse	1		
11	560833020001		Fuse	1		
12	560833020002		Copper Busbar	1		

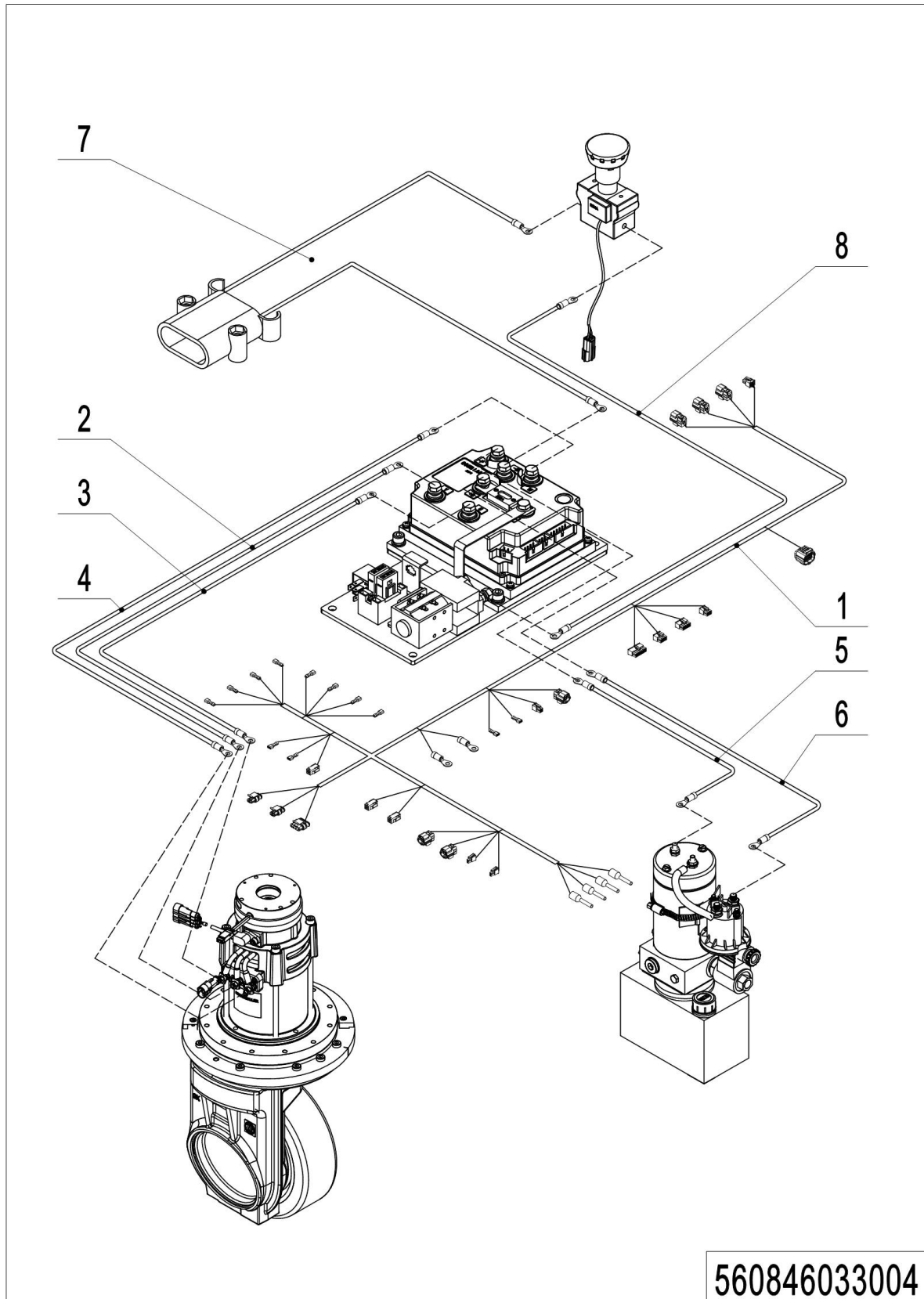
07 Wire Harness,COMBIACX (560846033004)

07 Wire Harness,COMBIACX (560846033004)

No.	Item Code	Mark	Item Description	Qty.	Substitute	Note
1	561133010000	2	Wire Harness	1		(COMBIACX+ Three-stage)
1	560833010000	2	Wire Harness	1		COMBIACX+210AH)
1	561133010021	2	Wire Harness			
1	560833010021	2	Wire Harness			210+Li
2	560833010002	2	Cable	1		
3	560833010003	2	Cable	1		
4	560833010004	2	Cable	1		
5	560833010005	2	Cable	1		COMBIACX+210AH
5	560833010014	2	Cable	1		
6	560833010006	2	Cable	1		COMBIACX+210AH
6	560833010015	2	Cable	1		
7	560833010007	2	Wire Harness	1		COMBIACX+210AH
7	561133010022	2	Wire Harness	1		210+Li
8	560833010008	2	Cable	1		

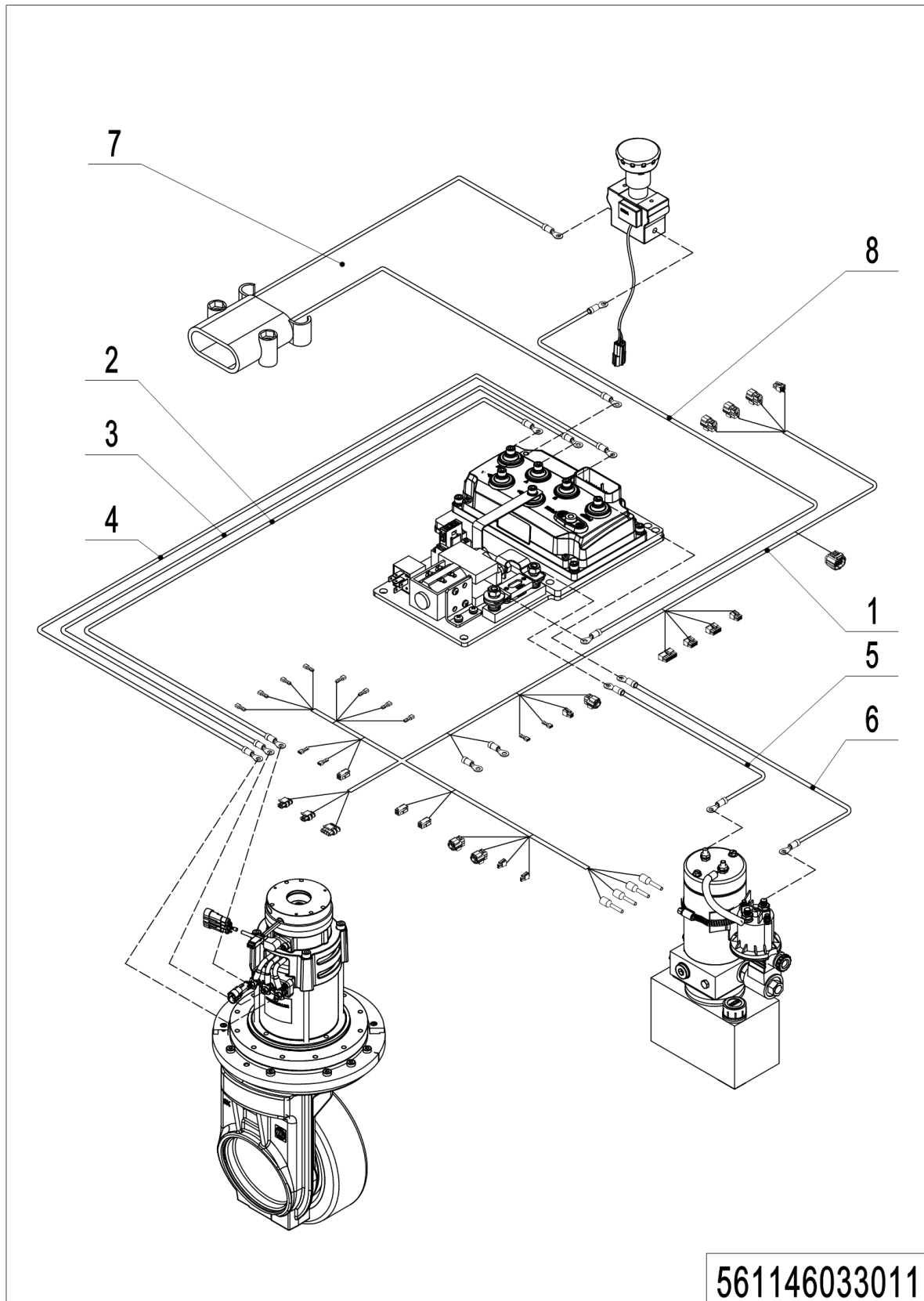
08 Wire Harness, Curtis-F(561146033011) (EN1175-2020)

1=整包供货

2=限制供货

3=逐渐停止供货

4=不单件供货

5=见另外表单

08 Wire Harness, Curtis-F (561146033011) (EN1175-2020)

No.	Item Code	Mark	Item Description	Qty.	Substitute	Note
1	561133010023	2	Wire Harness	1		
2	560833010030	2	Cable	1		
3	560833010031	2	Cable	1		
4	560833010032	2	Cable	1		
5	561133010024	2	Cable	1		
6	561133010025	2	Cable	1		
7	561133010026	2	Wire Harness	1		
7	561133010027	2	Wire Harness	1		Li
8	560833010037	2	Cable	1		

Chapter 8: Special Parts

01 Load Backrest (560846040502,PT20D One-stage)

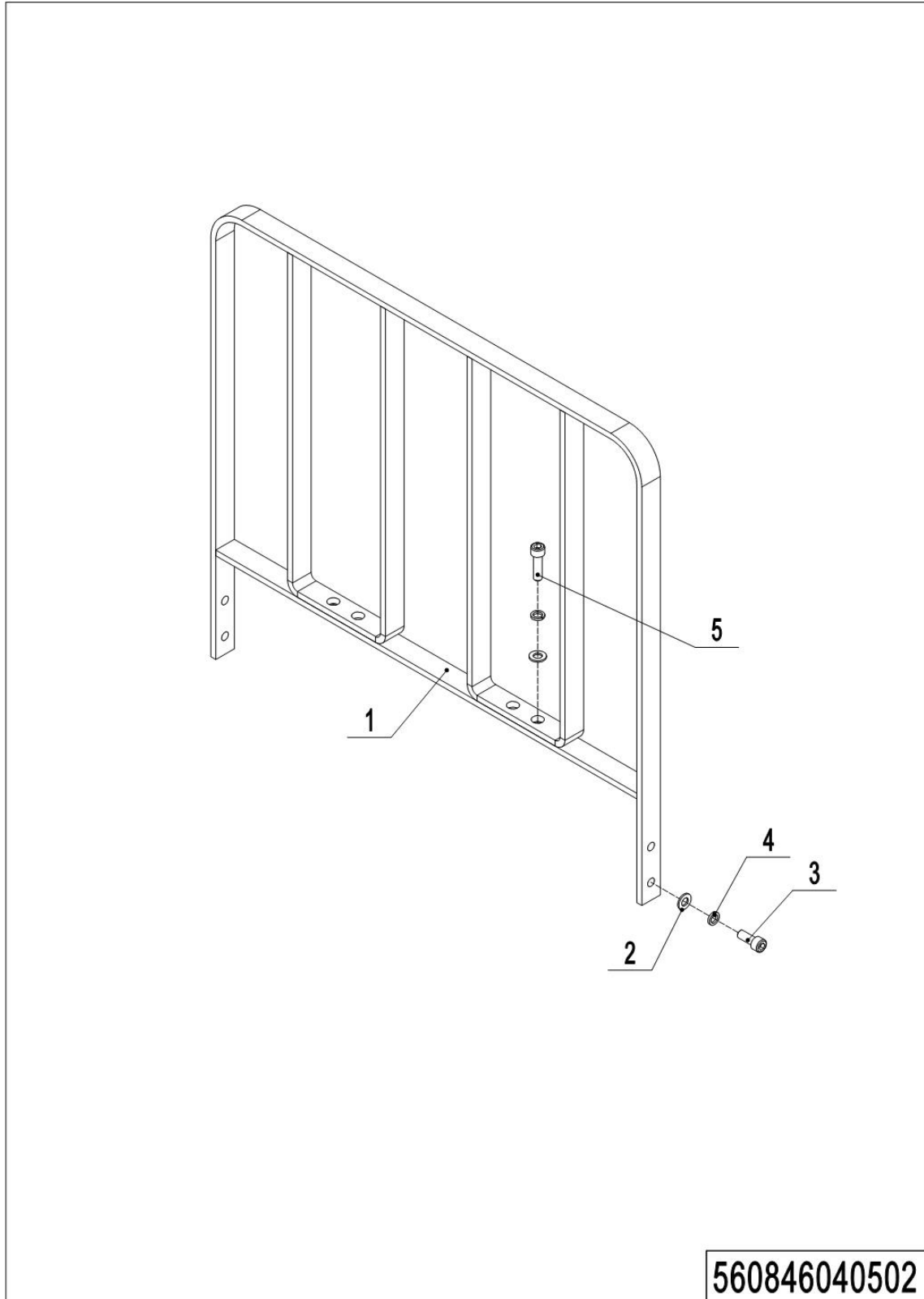

01 Load Backrest (560846040502,PT20D One-stage)

No.	Item Code	Mark	Item Description	Qty.	Substitute	Note
1	560840510000		Load Backrest	1		
2	910400100007		Flat Washer	4		
3	910200200076		Screw	2		
4	910400500007		Spring Washer	4		
5	910200200078		Screw	2		

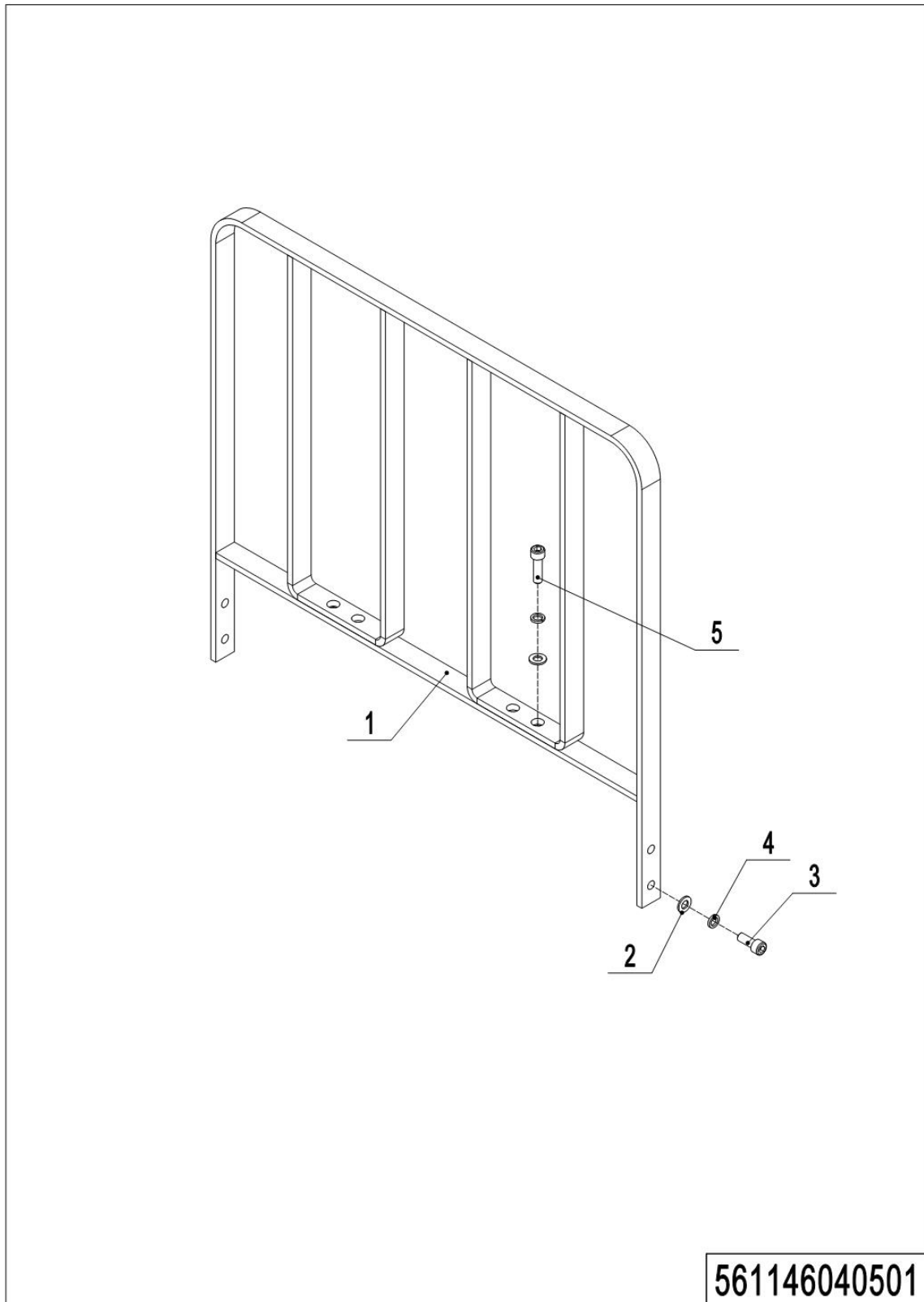
02 Load Backrest (561146040501,PT20D)

1=整包供货

2=限制供货

3=逐渐停止供货

4=不单件供货

5=见另外表单

02 Load Backrest (561146040501,PT20D)

No.	Item Code	Mark	Item Description	Qty.	Substitute	Note
1	561140510002		Load Backrest	1		1600/2500
1	561140510003		Load Backrest	1		2000
2	910400100007		Flat Washer	4		
3	910200200076		Screw	2		
4	910400500007		Spring Washer	4		
5	910200200078		Screw	2		

Chapter 9: Others

01 Labels and Decals-EU (560846047003,PT20D One-stage)

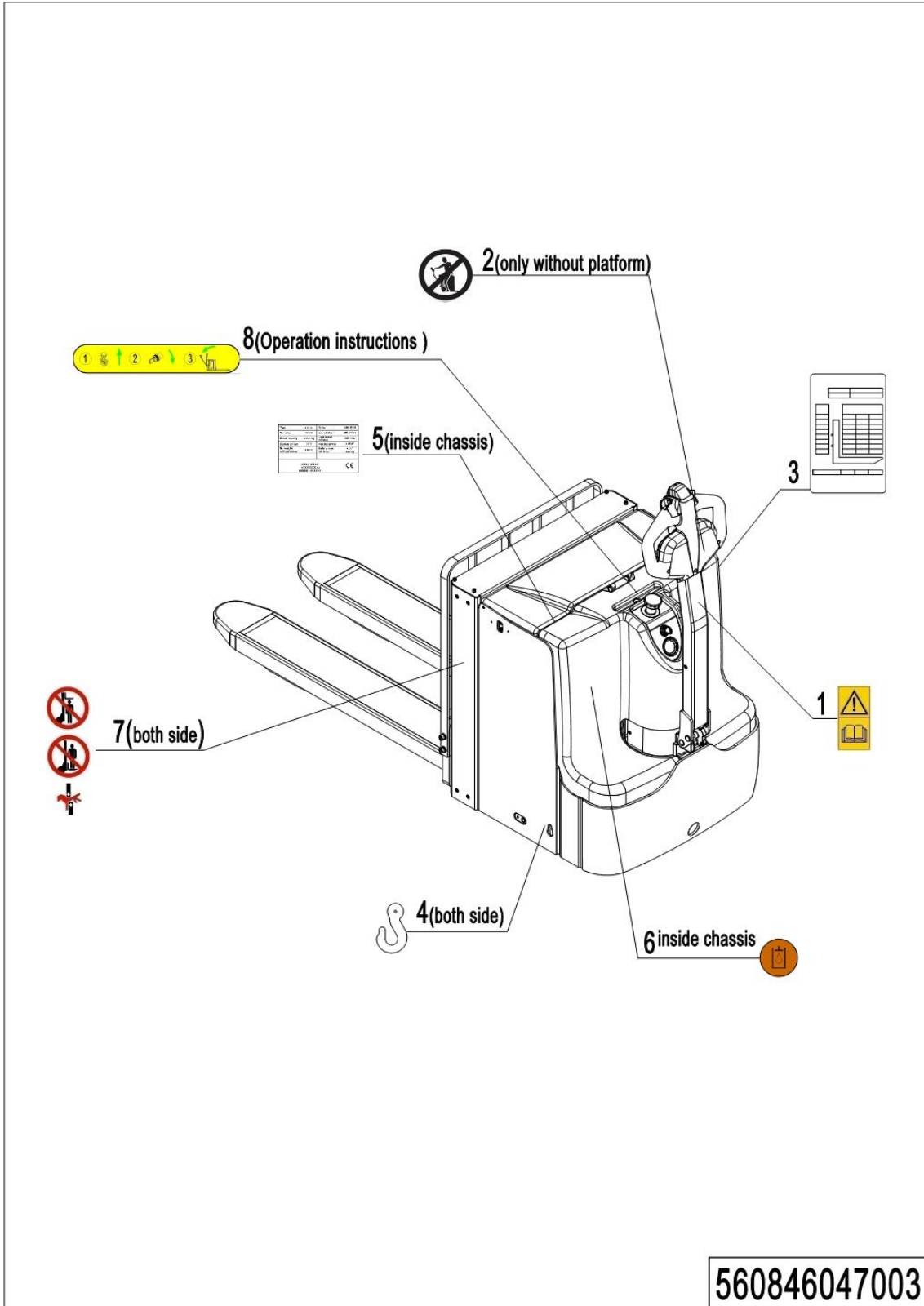

01 Labels and Decals-EU (560846047003,PT20D One-stage)

No.	Item Code	Mark	Item Description	Qty.	Substitute	Note
1	941200300002		Label	1		
2	941200100003		Label	1		
3	560847020001		Load Capacity Diagram	1		
4	941200300001		Label	2		
5	560847020000		Truck data plate	1		
6	941200300003		Label	1		
7	941200100004		Label	2		
8	560847020003		Label	1		

02 Labels and Decals-US (560846047004,PT20D One-stage)

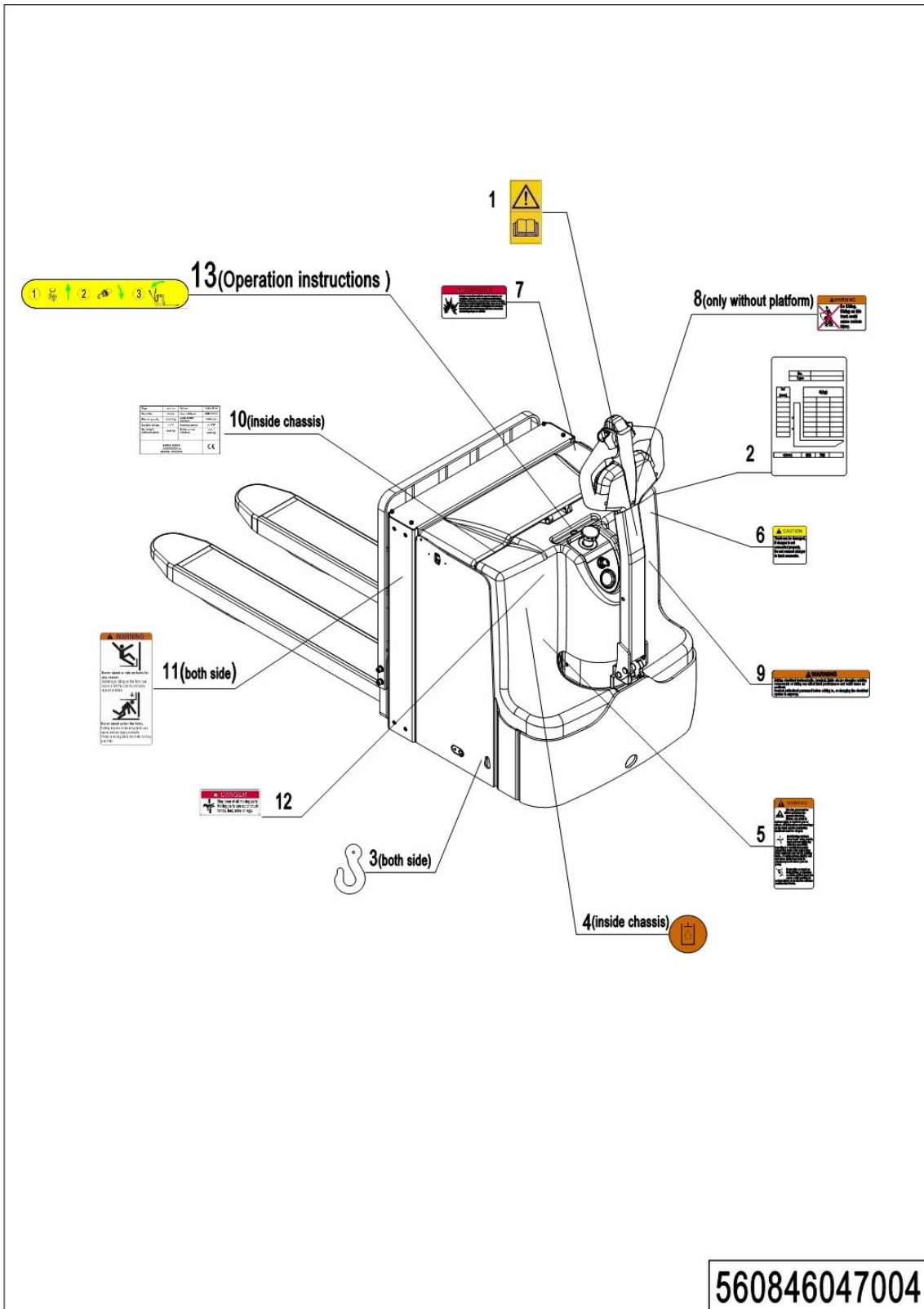

02 Labels and Decals-US (560846047004,PT20D One-stage)

No.	Item Code	Mark	Item Description	Qty.	Substitute	Note
1	941200300002		Label	1		
2	560847020001		Load Capacity Diagram	1		
3	941200300001		Label	2		
4	941200300003		Label	1		
5	941200100009		Label	1		
6	941200100012		Label	1		
7	941200100013		Label	1		
8	941200100011		Label	1		
9	941200100010		Label	1		
10	560847020002		Truck data plate	1		
11	941200100016		Label	2		
12	941200100014		Label	1		
13	560847020003		Label	1		

03 Labels and Decals-EU (561146047001,PT20D)

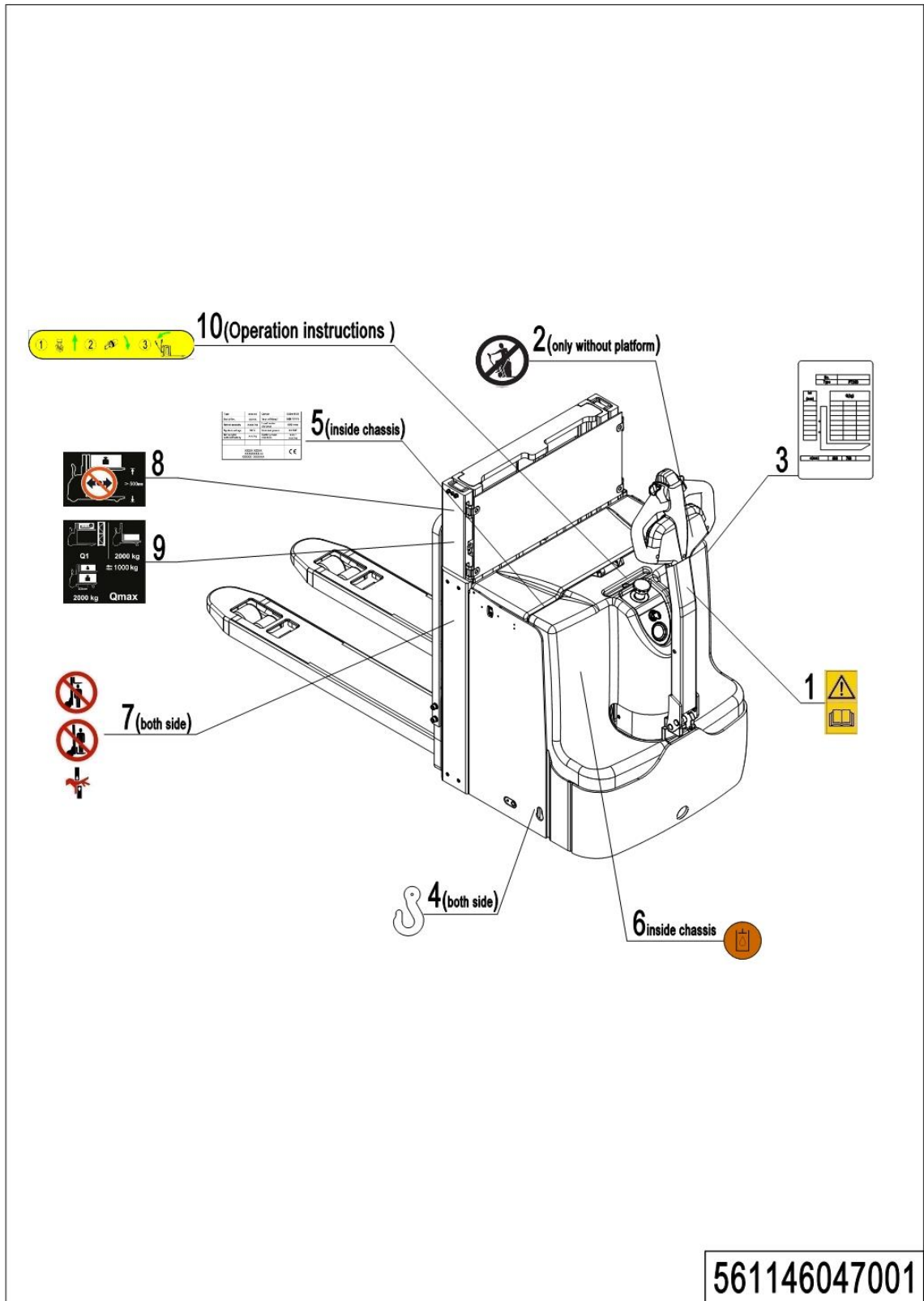

1=整包供货

2=限制供货

3=逐渐停止供货

4=不单件供货

5=见另外表单

03 Labels and Decals-EU (561146047001,PT20D)

No.	Item Code	Mark	Item Description	Qty.	Substitute	Note
1	941200300002		Label	1		
2	941200100003		Label	1		
3	561147020003		Load Capacity Diagram	1		
3	561147020004		Load Capacity Diagram	1		
3	561147020005		Load Capacity Diagram	1		
4	941200300001		Label	2		
5	561147020000		Truck data plate	1		
5	561147020001		Truck data plate	1		
5	561147020002		Truck data plate	1		
6	941200300003		Label	1		
7	941200100004		Label	2		
8	941200100031		Label	1		
9	941200200046		Label	1		
10	560847020003		Label	1		

04 Labels and Decals-US (561146047002,PT20D)

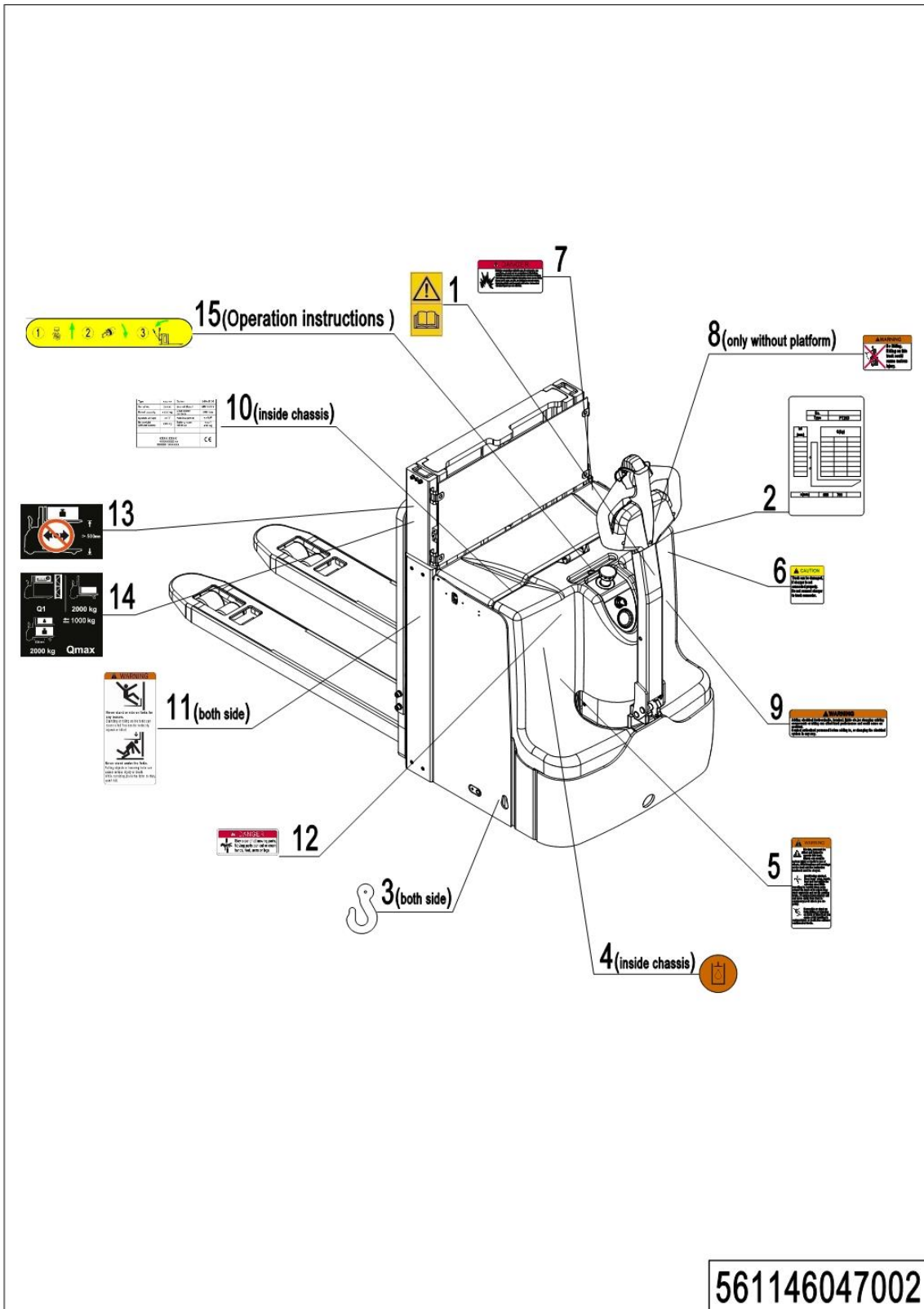

04 Labels and Decals-US (561146047002,PT20D)

No.	Item Code	Mark	Item Description	Qty.	Substitute	Note
1	941200300002		Label	1		
2	560847020001		Load Capacity Diagram	1		
3	941200300001		Label	2		
4	941200300003		Label	1		
5	941200100009		Label	1		
6	941200100012		Label	1		
7	941200100013		Label	1		
8	941200100011		Label	1		
9	941200100010		Label	1		
10	560847020002		Truck data plate	1		
11	941200100016		Label	2		
12	941200100014		Label	1		
13	941200100031		Label	1		
14	941200200046		Label	1		
15	560847020003		Label	1		

Appendix

01 Hydraulic Circuit Diagram (560846045501)

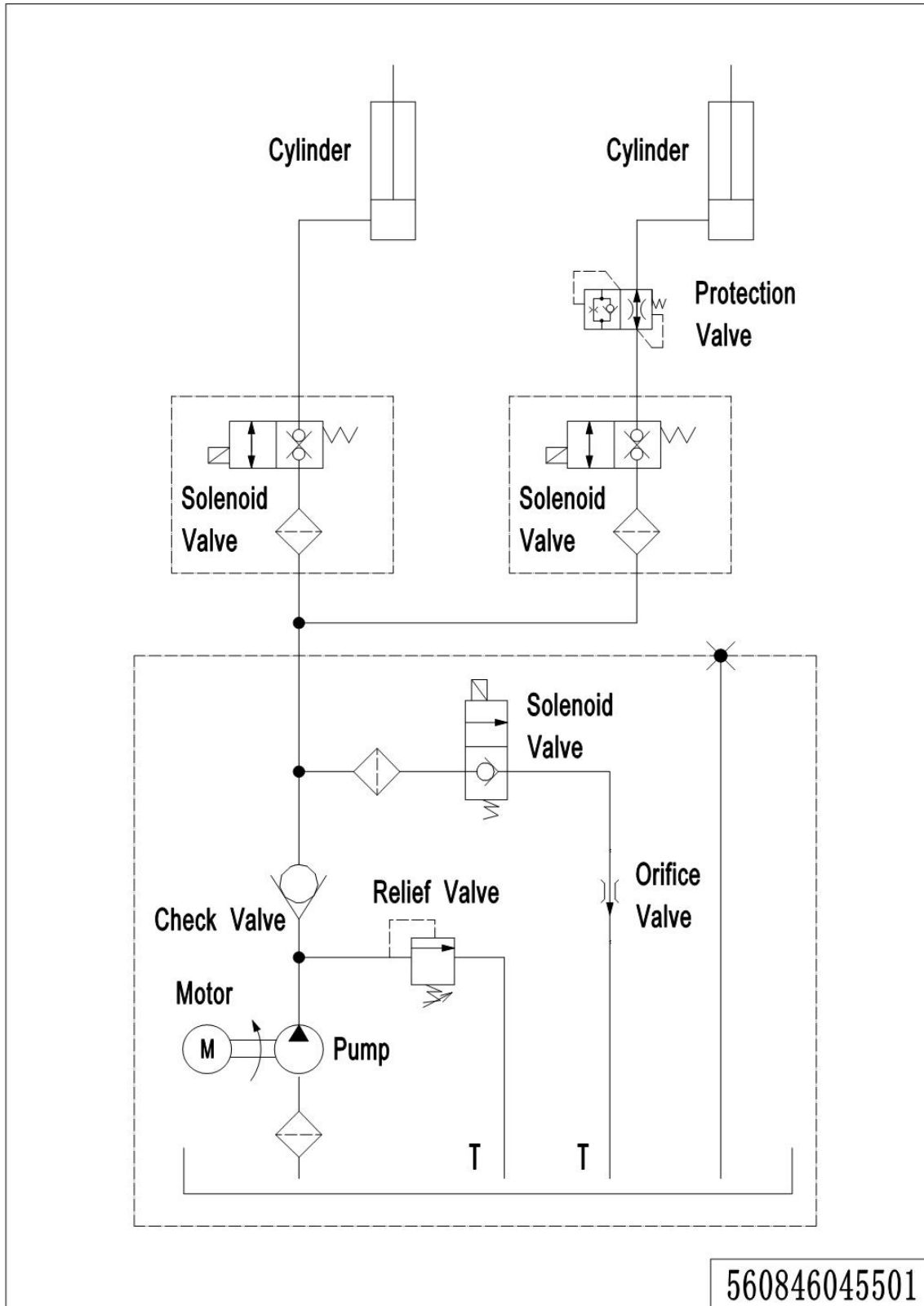

02 Electrical Circuit Diagram, COMBIACX (560846045502)

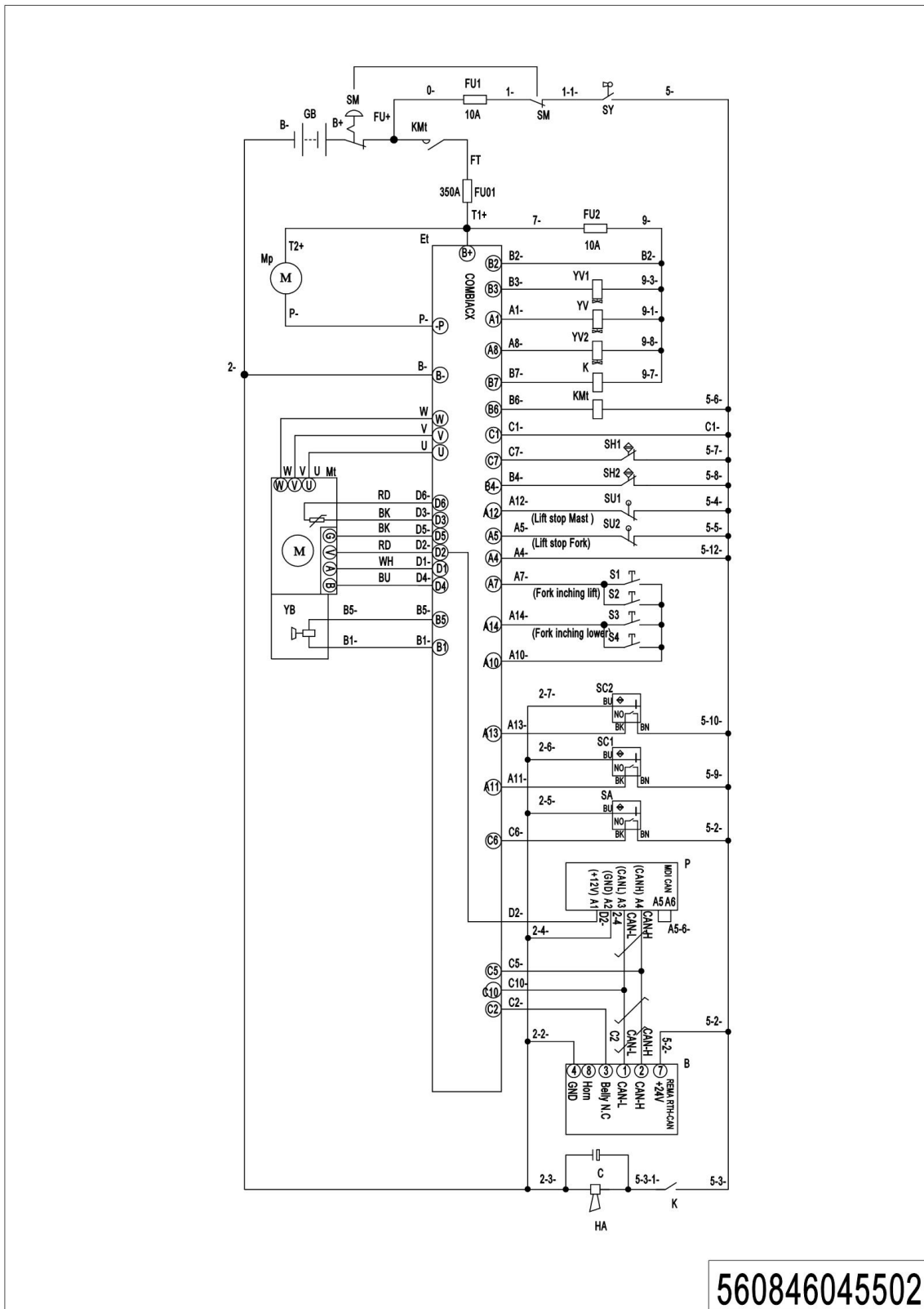

560846045502

03 Electrical Circuit Diagram, COMBIACX+Li (560846045503)

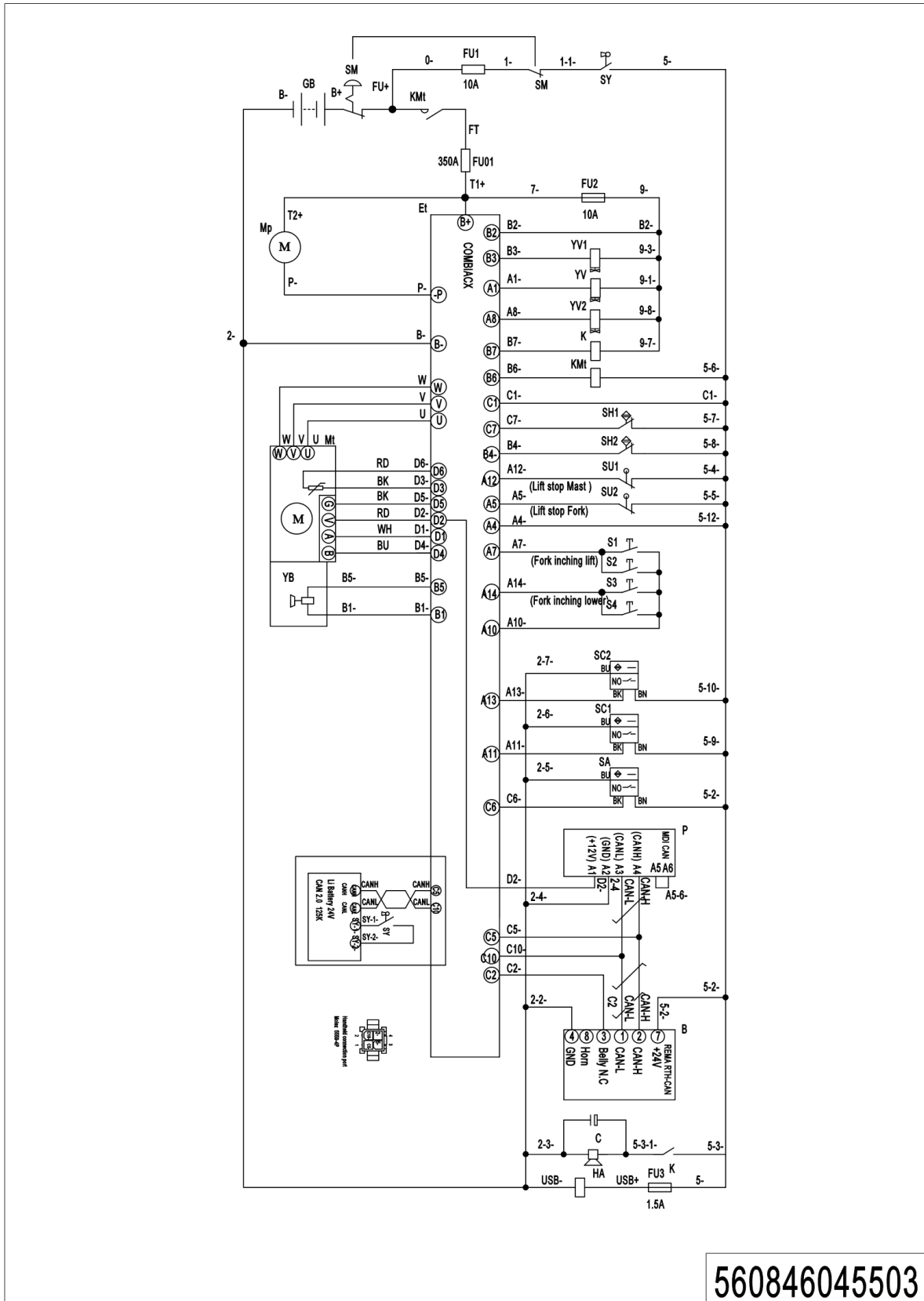

560846045503

04 Electrical Circuit Diagram, F2C (561146045501)

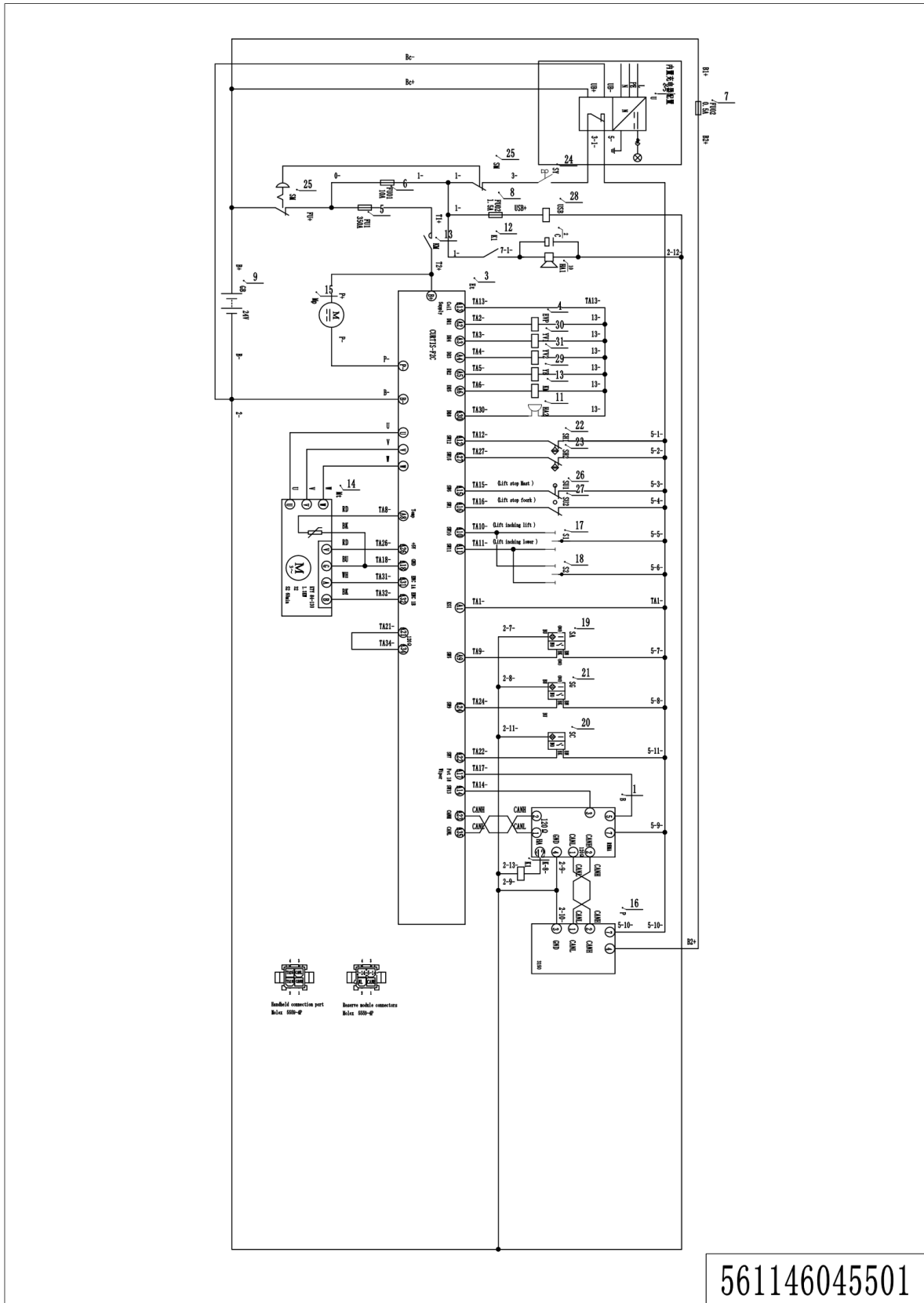

1=整包供货

2=限制供货

3=逐渐停止供货

4=不单件供货

5=见另外表单

05 Electrical Circuit Diagram, F2C+Li (561146045502)

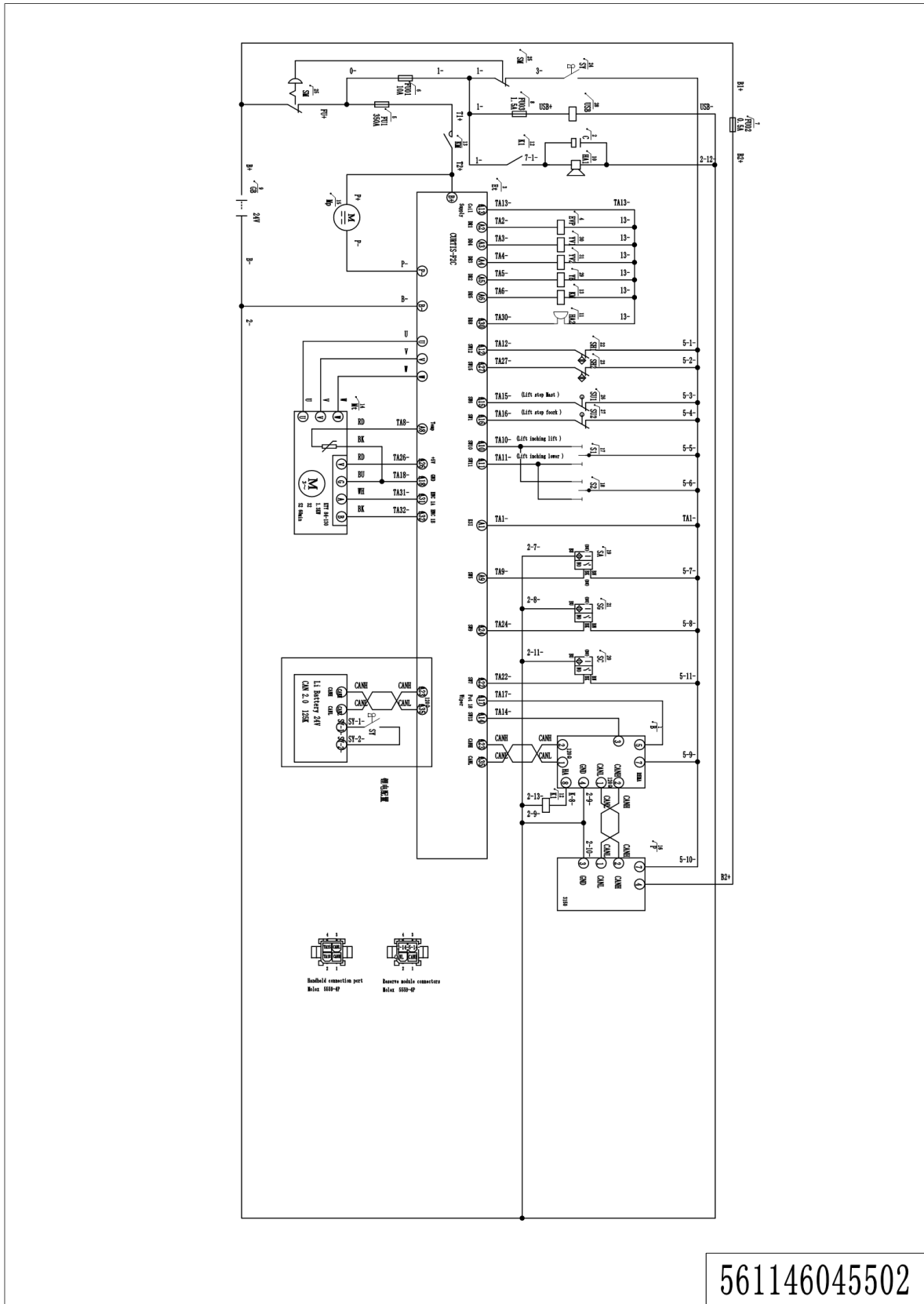

561146045502

06 Consumable Parts List

No.	Item Code	Item Description	Qty.	Chapter/ Section/ Number
1	560898520051	Carbon Brush	2	Chapter 2/03/20
2	940500100012	Bushing	16	Chapter 4/01/38 Chapter 4/02/34
3	940500100017	Bushing	4	Chapter 4/01/40 Chapter 4/01/36
4	940500200005	Bushing	4	Chapter 4/01/50 Chapter 4/01/46
5	910700200017	Bearing	12	Chapter 4/01/50 Chapter 4/01/47.03
6	910700200020	Bearing	8	Chapter 5/02/26 Chapter 5/02/27
7	940500200005	Bushing	2	Chapter 6/01/13
8	910700200019	Bearing	4	Chapter 6/03/3.01 Chapter 6/04/10.01
9	910700500002	Bearing	2	Chapter 6/04/2
10	920100200002	Fuse	2	Chapter 7/03/8
11	920100200002	Fuse	2	Chapter 7/03/11